

INSTALLATION INSTRUCTIONS

HCG*V SERIES AIR HANDLER

These instructions must be read and understood completely before attempting installation.



This is a safety alert symbol and should never be ignored. When you see this symbol on labels or in manuals, be alert to the potential for personal injury or death.

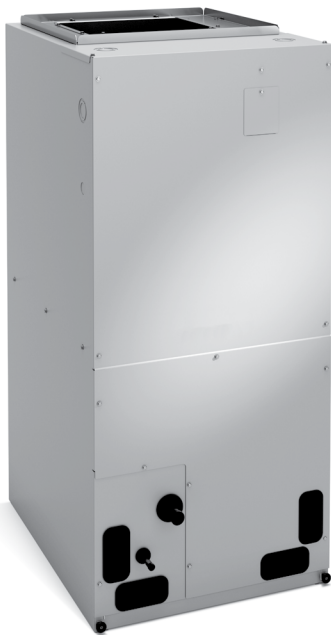

**THIS MANUAL MUST BE LEFT WITH THE
HOMEOWNER FOR FUTURE REFERENCE**

⚠ WARNING

Improper installation, adjustment, alteration, service or maintenance can cause property damage, personal injury or loss of life. Installation and service must be performed by a licensed professional installer (or equivalent), service agency or the gas supplier.

Table of Contents

Unit Dimensions	2
Shipping and Packing List	3
General	3
Requirements	3
Installation Clearances	4
Installation	4
Condensate Drain	8
Duct System and Filters	10
Brazing Refrigerant Lines	10
Sealing the Unit	13
Electrical Connections	13
Blower Control	17
Adjusting the Blower Speed	17
Check-Out Procedures	24
Maintenance	25
Cabinet Insulation	25
Use of Air Handler During Construction	25

⚠ WARNING

Product contains fiberglass wool.

Disturbing the insulation in this product during installation, maintenance, or repair will expose you to fiberglass wool. Breathing this may cause lung cancer. (Fiberglass wool is known to the State of California to cause cancer.)

Fiberglass wool may also cause respiratory, skin, and eye irritation.

To reduce exposure to this substance or for further information, consult material safety data sheets available from address shown below, or contact your supervisor.

Manufactured By
Comfort-Aire / Century
1900 Wellworth Ave.
Jackson, MI 49203



(P) 507720-01

Unit Dimensions

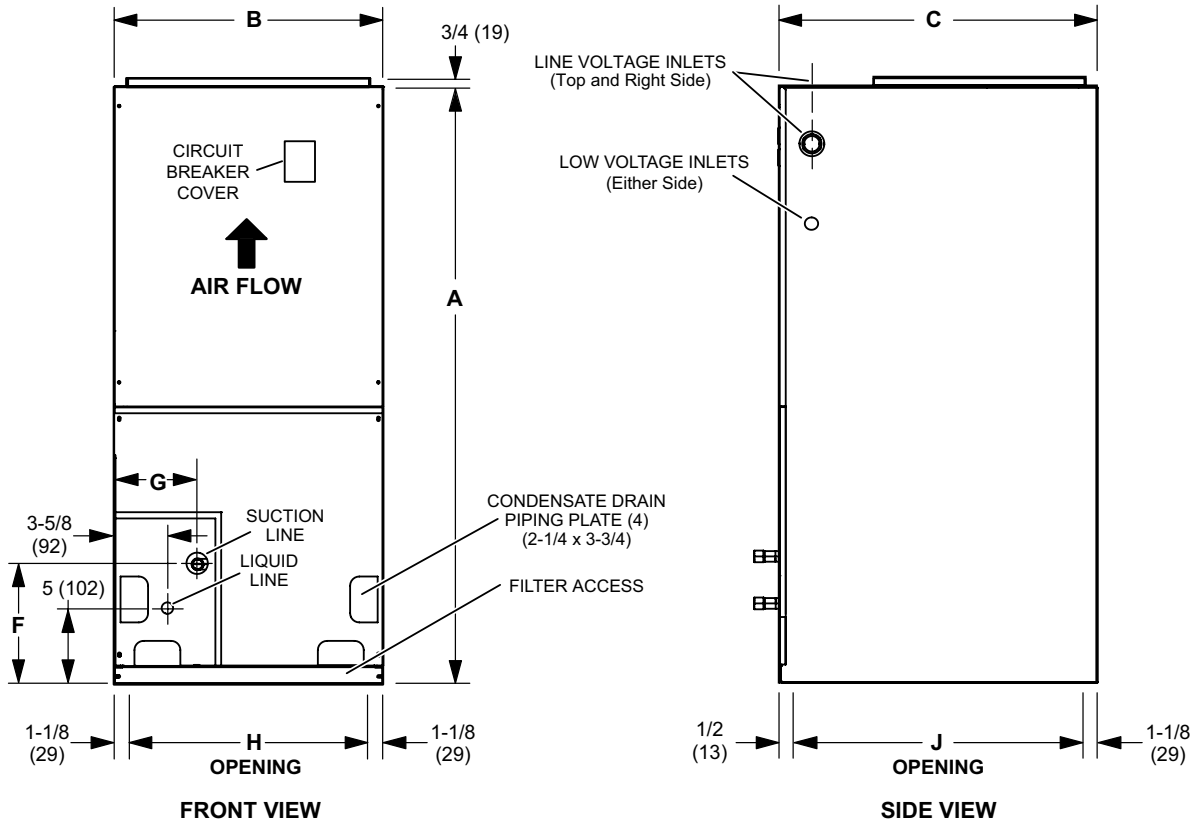
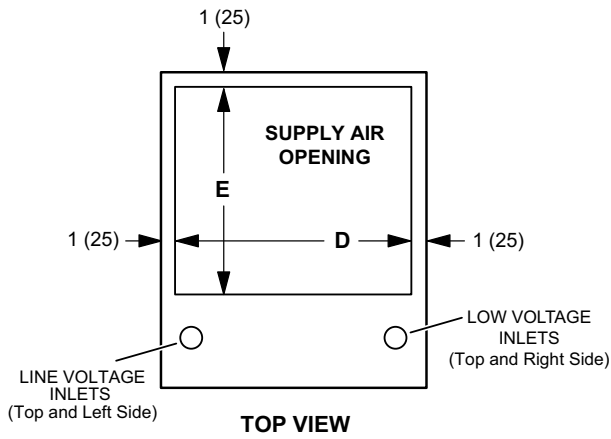

Dimension	024		036		042		048/060	
	in.	mm	in.	mm	in.	mm	in.	mm
A	40-1/2	1029	48	1334	48	1219	52-1/2	1334
B	18-1/2	470	21-7/8	556	21-7/8	556	21-7/8	556
C	22	559	22	559	26-1/4	667	26-1/4	667
D	16-1/2	419	19-7/8	505	19-7/8	505	19-7/8	505
E	14-1/2	368	14-1/2	368	18-3/4	476	18-3/4	476
F	8	203	8	203	9-1/4	235	9-1/4	235
G	5-5/8	143	5-5/8	143	4-1/2	114	4-1/2	114
H	16-1/4	413	19-5/8	498	19-5/8	498	19-5/8	498
J	20-3/8	518	20-3/8	518	24-5/8	625	24-5/8	625

Note: Unit is shipped configured for horizontal left-hand air discharge. Unit may be converted to horizontal right-hand air discharge by repositioning horizontal drain pan.

Dimensions remain the same in all configurations.

 **CAUTION**

The Clean Air Act of 1990 bans the intentional venting of refrigerant (CFCs, HCFCs and HFCs) as of July 1, 1992. Approved methods of recovery, recycling or reclaiming must be followed. Fines and/or incarceration may be levied for noncompliance.

NOTE: *These instructions are intended as a general guide and do not supersede national, state or local codes in any way.*

Shipping and Packing List

Package 1 of 1 contains the following:

1 - Assembled air handler unit factory-equipped for upflow or horizontal air discharge application (includes upflow and horizontal drain pans and pre-installed air filter).

Check equipment for shipping damage. If found, immediately report damage to the last carrier. Check the unit rating plate to confirm that delivered unit matches order.

General

The HCG*V air handler is designed for indoor installation only. As shipped, the unit is ready for installation in either upflow or horizontal left-hand air discharge applications. Horizontal drain pan may be repositioned in the field to allow installation in the horizontal right-hand air discharge position.

All units come with a metering device installed.

NOTE: *These units are not approved for downflow applications.*

 **WARNING**

This product contains a chemical known to the State of California to cause cancer, birth defects or other reproductive harm.

Requirements

 **IMPORTANT**

These units are designed to match, and must be used with, outdoor units as rated. The indoor sections are manufactured with a metering device installed to provide optimum refrigerant control and system performance with a variety of different capacities of outdoor units.

 **WARNING**

Excessive Weight Hazard - Use two or more people when moving and installing the unit. Failure to do so can result in back or other type of injury.

 **CAUTION**

Physical contact with metal edges and corners while applying excessive force or rapid motion can result in personal injury. Be aware of, and use caution when working near these areas during installation or while servicing this equipment.

These instructions are intended as a general guide and do not supersede local or national codes in any way. Consult authorities having jurisdiction before installation.

Compliance with all local, state, or national codes pertaining to this type of equipment should be determined prior to installation. Read this instruction manual, as well as the instructions supplied in separate equipment, before starting the installation.

In addition to conforming to manufacturer's installation instructions and local municipal building codes, installation of Comfort-Aire / Century air handler units (with or without optional electric heat), MUST conform with National Fire Protection Association (NFPA) standards: "Standard for Installation of Air Conditioning and Ventilation Systems" (NFPA No. 90A) and "Standard for Installation of Residence Type Warm Air Heating and Air Conditioning Systems" (NFPA No. 90B).

All models are designed for indoor installation only. The installation of the air handler, field wiring, duct system, etc. must conform to the requirements of the National Electrical Code, ANSI/NFPA No. 70 (latest edition) in the United States, and any state laws, and local ordinances (including plumbing or wastewater codes). Local authorities having jurisdiction should be consulted before installation is made. Such applicable regulations or requirements take precedence over the general instructions in this manual.

Install the conditioned air plenum, ducts and air filters (provided) in accordance with NFPA 90B Standard for the Installation of Warm Air Heating and Air-Conditioning Systems (latest edition).

The air handler is shipped from the factory completely assembled. This unit is provided with flanges for connecting the supply plenum.

Do not remove the cabinet knockouts until it has been determined which knockouts will need to be removed for the installation.

Select the air discharge position which best suits the site conditions. Consider required clearances, space, routing requirements for refrigerant line, condensate disposal, filters, duct system, wiring, and accessibility for service. Refer to the rating plate on the air handler for specific information.

WARNING



Danger of explosion. Keep flammable materials and vapors, such as gasoline, away from air handler. Place air handler so that heating elements are at least 18 inches (46 cm) above the floor for a garage installation. Failure to follow these instructions can result in death, explosion, or fire.

IMPORTANT

Excessive condensation may occur if the unit is installed in a warm, humid place. When the unit is installed in an unconditioned space, apply sealant around the electrical wires, refrigerant piping, and condensate lines at the point where they enter the cabinet.

Apply sealant on the inside of the cabinet at the point where the electrical wires exit through the conduit opening. This will also keep warm and moist unconditioned air out of the air handler cabinet where it will form condensate on the cooler control box and electrical controls.

IMPORTANT

Horizontal applications of the air handler must be installed sloped (approximately 5/8 inch) toward the drain pan openings to ensure proper condensate drainage.

IMPORTANT

This unit is approved for installation clearance to combustible material as stated on the unit rating plate. Accessibility and service clearances must take precedence over combustible material clearances.

The air handler must be installed so that free access is allowed to the coil/filter compartment and blower/control compartment.

Installation Clearances

Non-Ducted Return Closet Installation

The air handler can be installed in a closet with a false bottom to form a return air plenum. It may also be installed with a return air plenum under the air handler.

Louvers or return air grilles are field-supplied. Local codes may limit application of systems without a ducted return to single-story buildings.

When a HCG*V unit is installed in a closet with a louvered return opening, the minimum open area for the louvers will be:

- 320 square inches for -024 models;
- 360 square inches for -036 models;
- 450 square inches for -042 thru -060 models.

If the free area is not known, assume a 25% free area for wood or a 75% free area for metal louvers or grilles. Using the louver dimensions and the 25% or 75% assumption, determine if the open area meets the minimum open area listed above.

If a return air plenum is used, the return air grille should be immediately in front of the opening in the plenum to allow for the free flow of return air. When not installed in front of the opening, there must be adequate clearance around the air handler to allow for the free flow of return air.

Installation

General Information

WARNING

Improper installation, adjustment, alteration, service, or maintenance can cause property damage, personal injury, or loss of life. Installation and service must be performed by a qualified installer or service agency.

These units are factory-assembled and configured for installation in upflow or horizontal left-hand air discharge applications. Horizontal drain pan may be repositioned in the field to allow installation in the horizontal right-hand air discharge position.

Each unit consists of a blower assembly, refrigerant coil and controls in an insulated, galvanized steel factory-finished enclosure. Knockouts are provided for electrical wiring entrance.

For ease in installation, it is best to make any necessary coil configuration changes before setting air handler in place.

For all performance testing, units must be tested in the upflow orientation with the horizontal drain pan removed.

Refrigerant Metering Device

These units are equipped with a check/expansion valve, which is factory installed internal to the cabinet. Ensure the indoor coil TXV is properly sized for the outdoor unit being used.

Upflow Application

1. The air handler must be supported on the bottom only and set on a solid floor or a field-supplied support frame. Securely attach the air handler to the floor or support frame.
2. If installing a unit in an upflow application, remove the horizontal drain pan.

IMPORTANT - The horizontal drain pan is not required in upflow air discharge installations. It must be removed to provide the best efficiency and air flow.

3. Place the unit in the desired location and properly slope the unit (see page 7). Connect the return and supply air plenums as required using sheet metal screws.
4. In applications that do not include a return air plenum, install units on a stand that is raised at least 14" above the floor. This ensures proper air return.

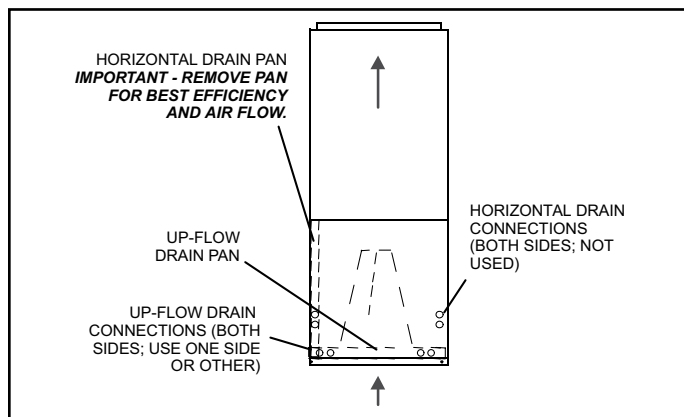

Figure 1. Upflow Configuration

Horizontal Applications

⚠ IMPORTANT

When removing the coil, there is possible danger of equipment damage and personal injury. Be careful when removing the coil assembly from a unit installed in right- or left-hand applications. The coil may tip into the drain pan once it is clear of the cabinet. Support the coil when removing it.

NOTE: When the unit is installed in horizontal applications, a secondary drain pan is recommended. Refer to local codes.

NOTE: This unit may be installed in left-hand or right-hand air discharge horizontal applications. Adequate support must be provided to ensure cabinet integrity. Ensure that there is adequate room to remove service and access panels if installing in the horizontal position.

Left-Hand Discharge

1. Determine which plugs are required for drain line connections.
2. With access door removed, remove drain line plugs to install drain lines.
3. Set unit so that it is sloped toward the end of the unit with the drain pan (see figure 11).
4. A typical left-hand air discharge horizontal configuration is shown in figure 2.

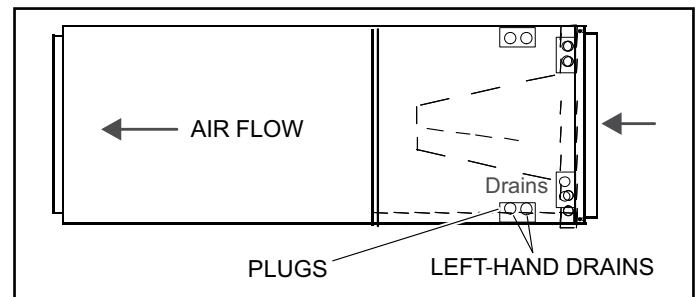

Figure 2. Left-Hand Discharge Configuration

5. If the unit is suspended, the entire length of the cabinet must be supported. If you use a chain or strap, use a piece of angle iron or sheet metal attached to the unit (either above or below) to support the length of the cabinet. Use securing screws no longer than 1/2 inch to avoid damaging the coil or filter. See figure 3. Use sheet metal screws to connect the return and supply air plenums as required.

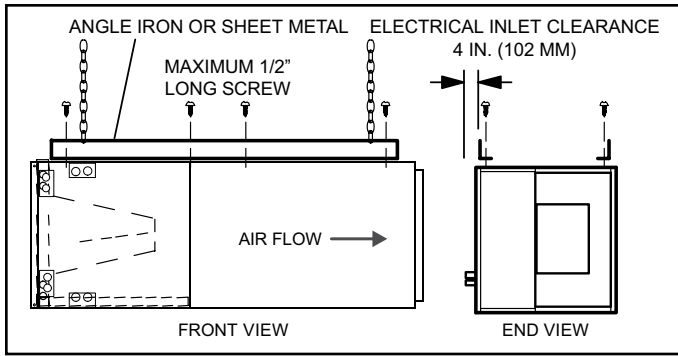

Figure 3. Suspending Horizontal Unit

Right-Hand Air Discharge

For horizontal right-hand air discharge, the following field modifications are required.

1. Remove and set aside blower and coil access panels.
2. Remove brackets securing pans to unit. See figure 4.

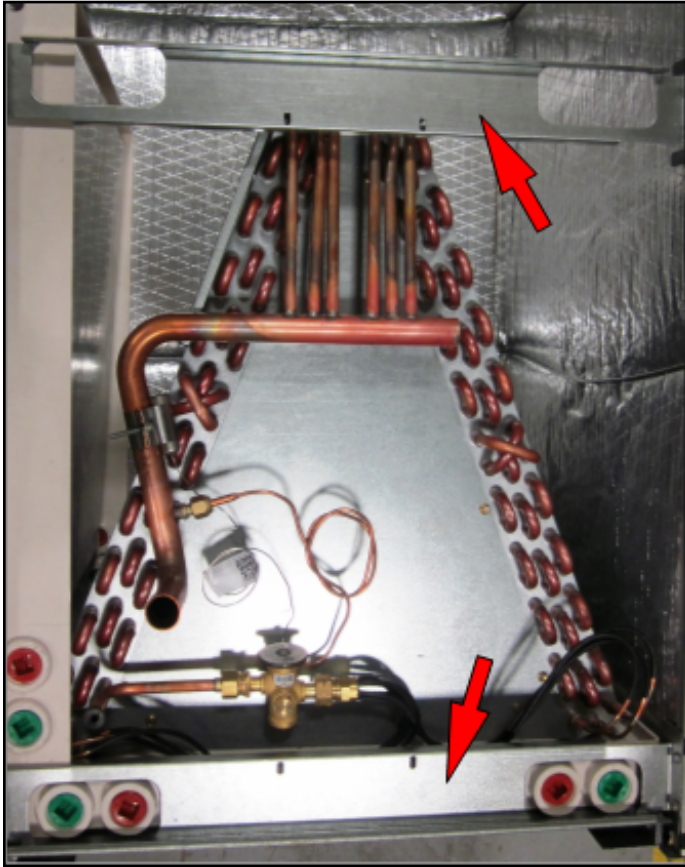

Figure 4

3. Remove coil assembly, bottom drain pan and horizontal drain pan as one unit from the air handler.
4. Remove the blow-off prevention brackets, top cap and drip pan between slabs. Move the horizontal drain pan to the opposite side of the coil.

NOTE: The 2-ton unit does not have or require blow-off prevention brackets or drip pan.

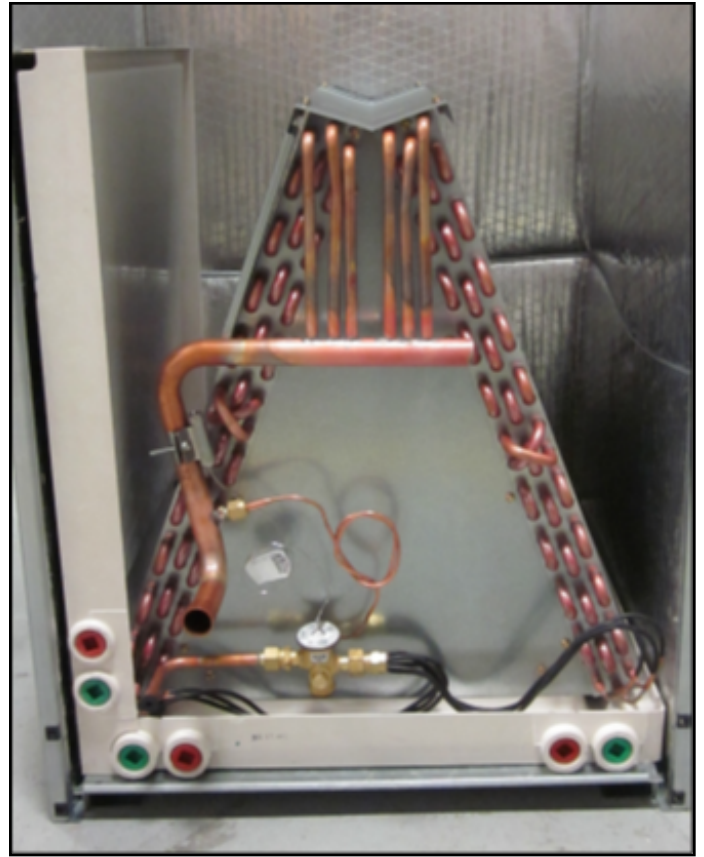

Figure 5

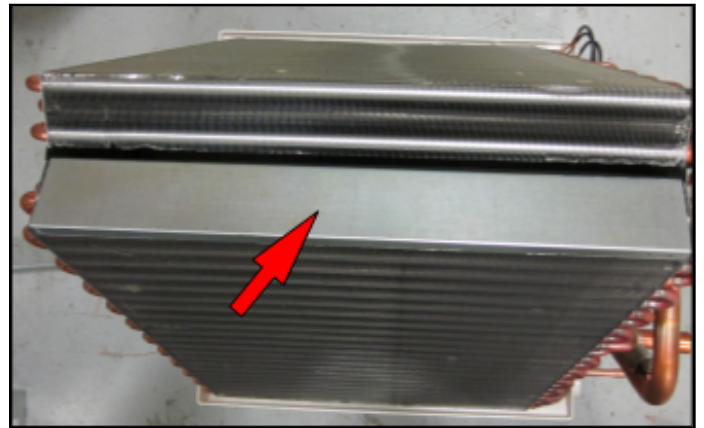

Figure 6

5. Reinstall the top cap. Rotate the blow-off prevention brackets 180° and reinstall using the same screws. Use the correct mounting holes; the brackets must cover the hairpins. See figure 7.

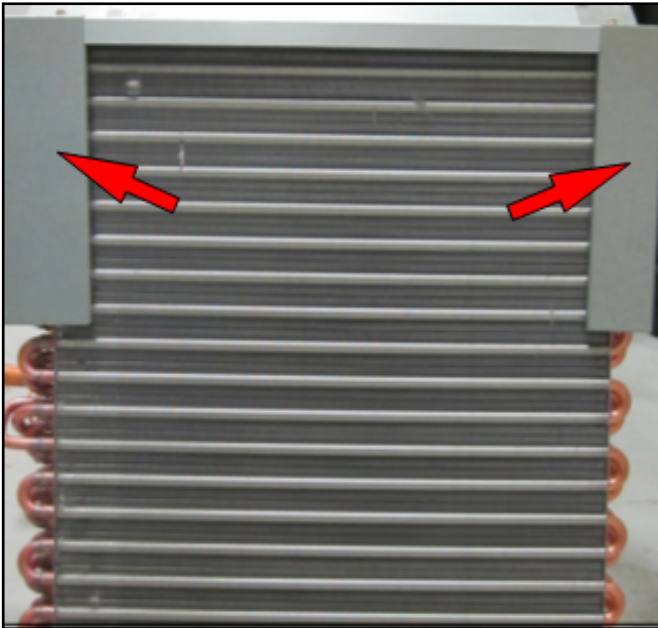

Figure 7

6. Slide coil assembly, bottom drain pan and horizontal drain pan as one unit back into the air handler. See figure 8.

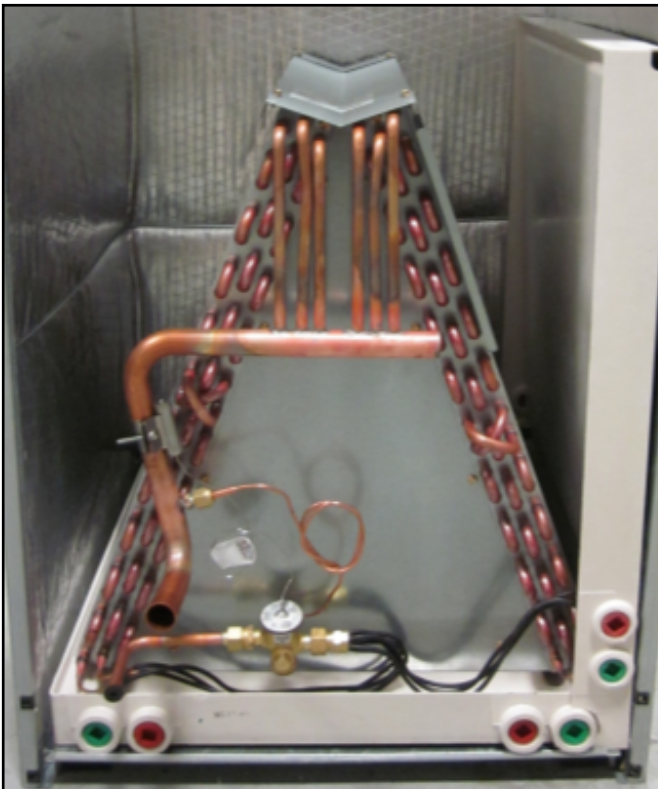

Figure 8

7. Reinstall the brackets that hold the coil and horizontal drain pan in place. See figure 9.



Figure 9

8. Reinstall the blower and coil access panels.

Condensate Drain

The air handler is provided with 3/4" NPT condensate drain connections.



IMPORTANT

On units of this type, where the blower "draws" rather than "blows" air through the coil, traps must be installed in the condensate drain lines (primary and auxiliary, if used). Traps prevent the blower from drawing air through the drain lines into the air supply.

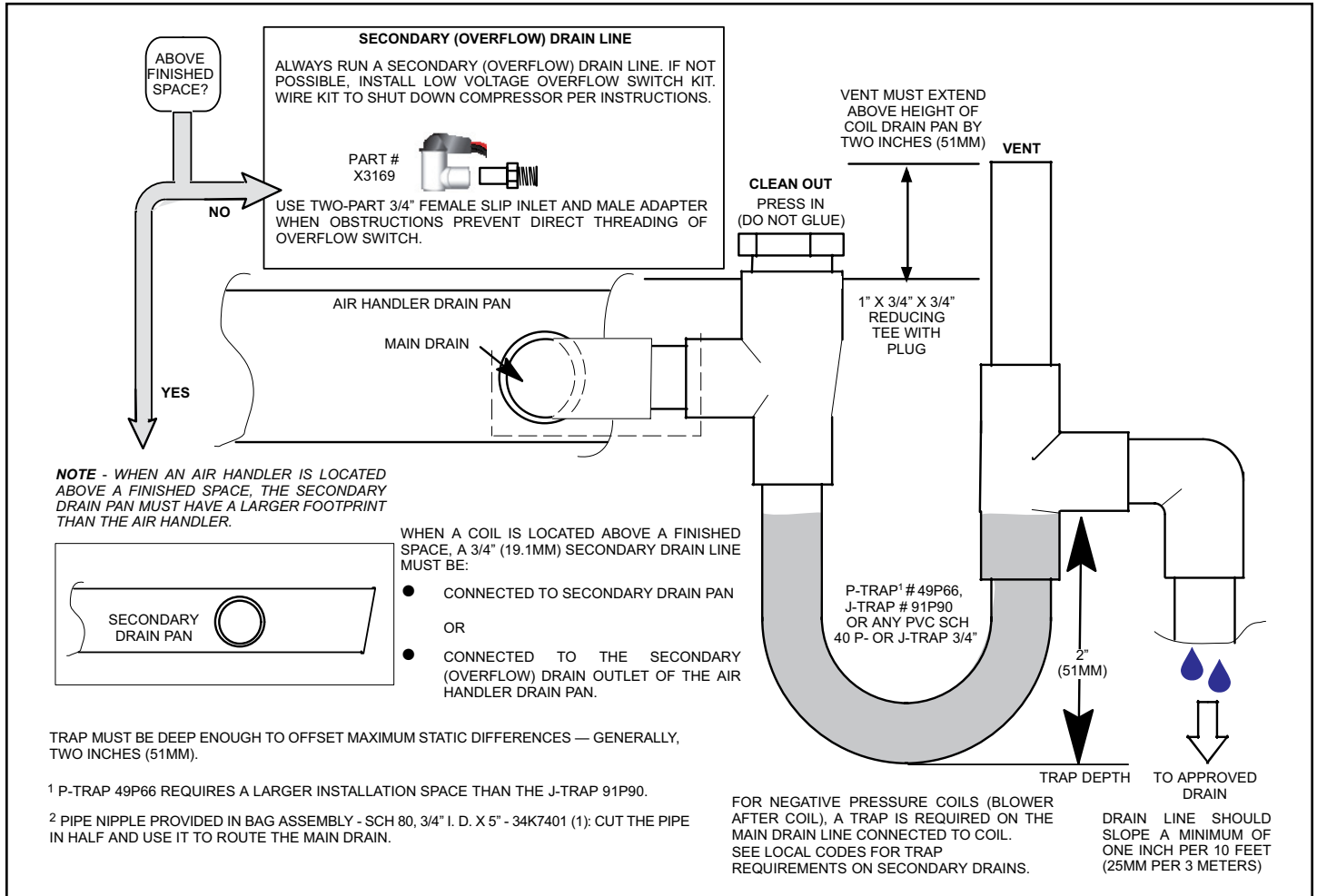

Figure 10. Typical Main and Overflow Drain



IMPORTANT

A field-fabricated secondary drain pan, with a drain pipe to the outside of the building, is required in all installations over a finished living space or in any area that may be damaged by overflow from the main drain pan. In some localities, local codes may require a secondary drain pan for any horizontal installation.

Sloping the Unit

Make sure the unit is sloped (similar to the slope shown in figure 11) (horizontal or upflow) so that the drain pan will empty completely without water standing in the pan.

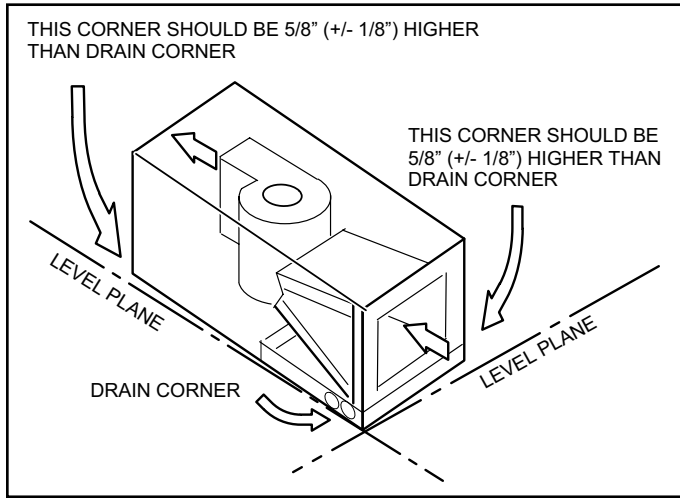

Figure 11. Sloping the Drain

Install Condensate Drain

The air handler is equipped with 3/4" NPT condensate drain connections.

⚠ IMPORTANT

On some pans, the primary and secondary drain holes have knockouts. Confirm primary and secondary drains are open.

1. HCG*V units are equipped with a drain pan, which includes green (main drain) and red (secondary drain) plugs. Unscrew the plugs to remove them before inserting condensate drain fittings.

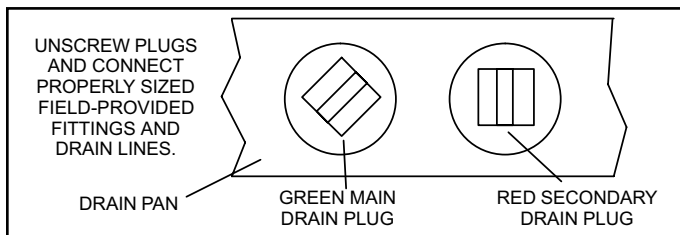

Figure 12

2. After removal of drain pan plugs, check the drain port to see if holes have been drilled. If not drilled, use a 19/32" bit to drill out the primary drain hole; use a 3/8" drill bit for the secondary drain hole. Remove all drill shavings.
3. Install properly sized, field-provided connection fittings and connect primary drain line to the main drain pan connection.

NOTE: When installing drain line connection fittings to the drain pan, hand tighten the fitting and use a thread sealant. Over-tightening the fittings can split connections on the drain pan.

4. If the secondary drain line is to be used, remove the plug or the knockout and route the drain line so that water draining from the outlet will be easily noticed by the homeowner. Refer to local codes for drain trap requirements on the secondary drain line.
5. Check again to ensure drain ports and drain pan are free of all debris.
6. Plug and check any unused drain pan openings for tightness. Torque plugs to 30 in. lb. to prevent water leaks or seepage from the drain pan.
7. Install a 2" trap in the main (primary) drain lines as close to the unit as practical (see figure 10). Make sure the top of the trap is below the connection to the drain pan to allow complete drainage of the pan.

NOTE: Horizontal runs must have an anti-siphon air vent (standpipe) installed ahead of the horizontal run. See figure 10. An extremely long horizontal run may require an oversized drain line to eliminate air traps.

NOTE: Do not operate air handler without a trap in the main (primary) drain. The condensate drain is on the negative pressure side of the blower; therefore, air being pulled through the condensate line will not allow positive drainage without a proper trap.

8. Route the drain line to the outside or to an appropriate drain. Drain lines must be installed so they do not block service access to the front of the air handler. A 24" clearance is required for filter, coil, or blower removal and service access.
9. Insulate the drain lines where sweating could cause water damage.

Test Condensate Drain

Test the drain pan and drain line after installation:

1. Pour several quarts of water into drain pan. Use enough water to fill both the drain trap and the line.
2. Check the installed drain pan. Drain pan must drain completely. Drain line fittings must not leak. Water must drain from the end of the primary drain line.
3. Correct any leaks found.

Duct System and Filters

Duct System

The air handler is provided with flanges for the connection of the supply plenum and ducts. The air handler is equipped with flanges that can form a filter rack for the installation of the air filter, or the filter may be installed as part of the return air duct system.

Supply and return duct system must be adequately sized to meet the system's air requirements and static pressure capabilities. The duct system should be insulated with a minimum of 1" thick insulation with a vapor barrier in conditioned areas or 2" minimum in unconditioned areas.

Supply plenum should be the same size as the flanged opening provided around the blower outlet and should extend at least 3 ft. from the air handler before turning or branching off plenum into duct runs. The plenum forms an extension of the blower housing and minimizes air expansion losses from the blower.

Filters

A filter is provided. Table 2 lists the filter size for each unit.

Table 1

Capacity	Filter Size	Actual Minimum Filter Size
-024	15" x 20" x 1	14.50" x 19.50" x .75"
-036	18" x 20" x 1	17.50" x 19.50" x .75"
-042, -048 and -060	18" x 24" x 1	17.50" x 23.50" x .75"

⚠ IMPORTANT

If a high-efficiency filter is being installed as part of this system to ensure better indoor air quality, the filter must be properly sized. High-efficiency filters have a higher static pressure drop than standard-efficiency glass/foam filters. If the pressure drop is too great, system capacity and performance may be reduced. The pressure drop may also cause the limit to trip more frequently during the winter and the indoor coil to freeze in the summer, resulting in an increase in the number of service calls.

Before using any filter with this system, check the specifications provided by the filter manufacturer against the data given in the appropriate Comfort-Aire / Century Product Specifications bulletin.

Installing Duct System

Install the conditioned air plenum, ducts and air filters (not provided) in accordance with NFPA 90B Standard for the Installation of Warm Air Heating and Air-Conditioning Systems (latest edition).

Connect supply air duct to the flange on top of the air handler. If an isolation connector is used, it must be nonflammable.

Field-Fabricated Return Air Duct Flange for Horizontal Applications

A return air duct system is recommended, but not factory-provided. If the unit is installed in a confined space or closet, run a full-size return connection to a location outside the closet.

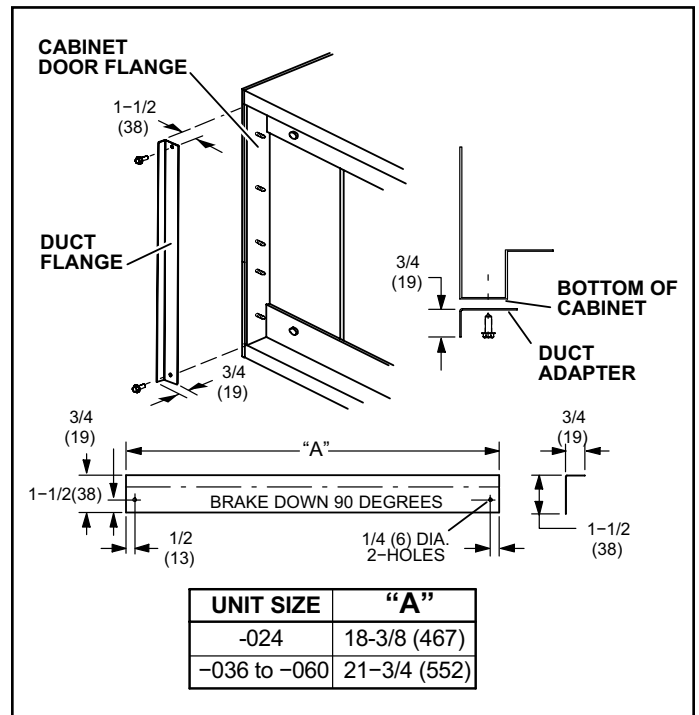

Figure 13. Cabinet and Duct Flange

Brazing Refrigerant Lines

Refrigerant lines must be connected by a qualified technician in accordance with established procedures.

⚠ WARNING



Danger of fire. Bleeding the refrigerant charge from only the high side may result in the low side shell and suction tubing being pressurized. Application of a brazing torch while pressurized may result in ignition of the refrigerant and oil mixture - check the high and low pressures before unbrazing.

⚠ IMPORTANT

Refrigerant lines must be clean, dehydrated, refrigerant-grade copper lines. Air handler coils should be installed only with specified line sizes for approved system combinations.

Handle the refrigerant lines gently during the installation process. Sharp bends or possible kinking in the lines will cause a restriction.

Do not remove the caps from the lines or system connection points until connections are ready to be completed.

⚠ WARNING

Polyolester (POE) oils used with HFC-410A refrigerant absorb moisture very quickly. It is very important that the refrigerant system be kept closed as much as possible. DO NOT remove line set caps or service valve stub caps until you are ready to make connections.

⚠ WARNING



When using a high pressure gas such as dry nitrogen to pressurize a refrigeration or air conditioning system, use a regulator that can control the pressure down to 1 or 2 psig (6.9 to 13.8 kPa).

⚠ IMPORTANT

To prevent the build-up of high levels of nitrogen when purging, be sure it is done in a well ventilated area. Purge low pressure nitrogen (1 to 2 psig) through the refrigerant piping during brazing. This will help to prevent oxidation and the introduction of moisture into a system.

⚠ CAUTION

Brazing alloys and flux contain materials which are hazardous to your health.

Avoid breathing vapors or fumes from brazing operations. Perform operations only in well ventilated areas.

Wear gloves and protective goggles or face shield to protect against burns.

Wash hands with soap and water after handling brazing alloys and flux.

NOTE: Recommended line length is 50' or less. If more than 50' line set is required, contact Technical Services.

1. Route the suction and liquid lines from the fittings on the indoor coil to the fittings on the outdoor unit. Run the lines in a direct path, avoiding unnecessary turns and bends.
2. Make sure that the suction line is insulated over the entire exposed length and that neither suction nor liquid lines are in direct contact with floors, walls, duct system, floor joists, or other piping.
3. To avoid damaging the rubber grommets in the cabinet while brazing, slide the rubber grommets over the refrigerant lines until they are away from the heat source.

NOTE: Place wet rags against piping plate and around suction line connections.

4. Connect the suction and liquid lines to the evaporator coil. Take care to protect the cabinet and internal components as detailed in figure 14.
5. Braze using an alloy of silver or copper and phosphorus with a melting point above 1,100°F (593°C).

NOTE: Do not use soft solder.

6. Allow refrigerant pipes to cool to room temperature.
7. Reinstall the rubber grommets into the refrigerant piping panel.

NOTE: Make sure expansion valve capillary tube is not touching metal edges or copper tubing.

8. Make sure outdoor unit has been placed according to the Installation Instructions and is connected to the refrigerant lines.

PLEASE READ IMPORTANT ISSUES CONCERNING BRAZING OPERATIONS ON PREVIOUS PAGES BEFORE PROCEEDING.

NOTE - REFER TO OUTDOOR UNIT INSTALLATION INSTRUCTIONS FOR REFRIGERANT PIPING SIZE REQUIREMENTS.

NOTE - Use silver alloy brazing rods with five or six percent minimum silver alloy for copper-to-copper brazing, 45 percent alloy for copper-to-brass and copper-to-steel brazing.

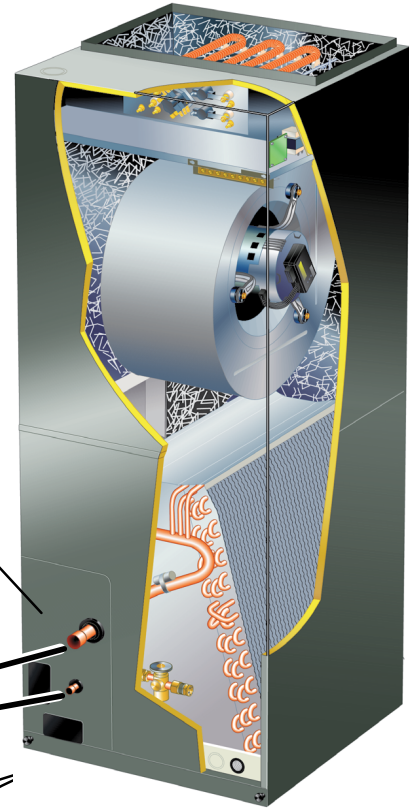

A REMOVE ACCESS PANEL

B REMOVE RUBBER PLUG FROM BOTH LIQUID AND SUCTION LINES

*NOTE - HCG*V SERIES UNITS USE NITROGEN OR DRY AIR AS A HOLDING CHARGE. IF THERE IS NO PRESSURE WHEN THE RUBBER PLUGS ARE REMOVED, CHECK THE COIL FOR LEAKS BEFORE INSTALLING.*

C EITHER REMOVE OR PUSH PIPE WRAPPING BACK THROUGH HOLE IN PIPING PLATE BEFORE LINE SET CONNECTION AND BRAZING.

D CONNECT PIPES

NOTE - REFRIGERANT LINE SETS SHOULD BE ROUTED TO ALLOW FILTER ACCESSIBILITY.

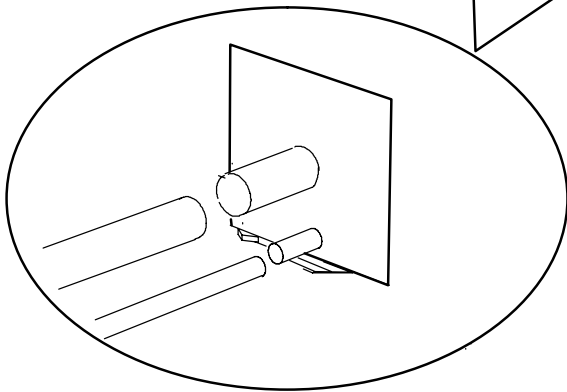

PIPING PLATE

E CONNECT GAUGES AND START NITROGEN FLOW

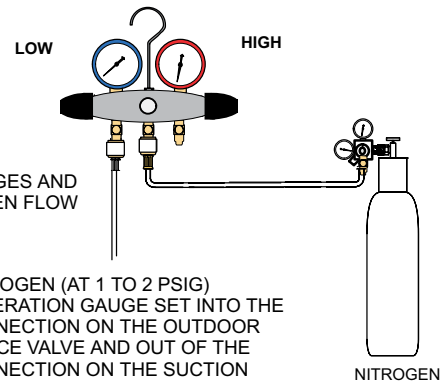

FLOW REGULATED NITROGEN (AT 1 TO 2 PSIG) THROUGH THE REFRIGERATION GAUGE SET INTO THE VALVE STEM PORT CONNECTION ON THE OUTDOOR UNIT LIQUID LINE SERVICE VALVE AND OUT OF THE VALVE STEM PORT CONNECTION ON THE SUCTION SERVICE VALVE.

F PLACE A WET RAG AGAINST PIPING PLATE AND AROUND THE SUCTION LINE CONNECTION. A

G BRAZE CONNECTION. ALLOW PIPE TO COOL BEFORE REMOVING WET RAG FROM CTXV SENSING BULB AND PIPING PANEL AREA.

H REPEAT PREVIOUS PROCEDURE FOR LIQUID LINE.

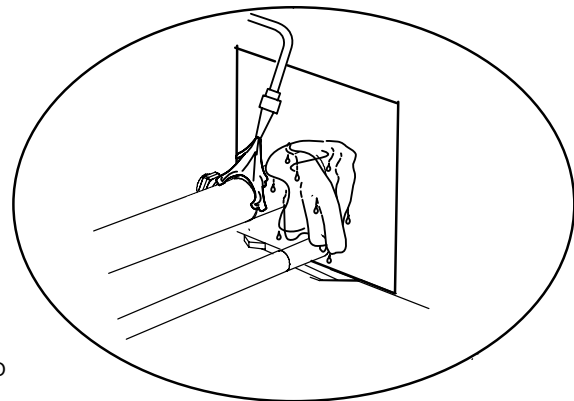

REFER TO INSTRUCTIONS PROVIDED WITH OUTDOOR UNIT FOR LEAK TESTING, EVACUATING AND CHARGING PROCEDURES

Figure 14

Sealing the Unit

Seal the unit so that warm air is not allowed into the cabinet. Warm air introduces moisture, which results in water blow-off problems. This is especially important when the unit is installed in an unconditioned area.

If installed in an unconditioned space, sealant should be applied around the electrical wires, refrigerant tubing, and condensate lines where they enter the cabinet.

WARNING

There must be an airtight seal between the bottom of the air handler and the return air plenum. Use fiberglass sealing strips, caulking, or equivalent sealing method between the plenum and the air handler cabinet to ensure a tight seal. Return air must not be drawn from a room where this air handler or any gas-fueled appliance (ie., water heater), or carbon monoxide-producing device (ie., wood fireplace) is installed.

IMPORTANT

When sealing the cabinet, be sure to seal closed any space around the holes where the drain lines exit the cabinet using duct tape and/or Permagum. Warm air must not be allowed to enter through any gaps or holes in the cabinet.

IMPORTANT

Make sure the liquid line and suction line entry points are sealed with either Armaflex material or with Permagum. Permagum may also be used to seal around the main and auxiliary drains and around open areas of electrical inlets.

Electrical Connections

WARNING



Electric shock hazard! - Disconnect all power supplies before servicing.

Replace all parts and panels before operating.

Failure to do so can result in death or electrical shock.

WARNING

Run 24V Class II wiring only through specified low voltage opening. Run line voltage wiring only through specified high voltage opening. Do not combine voltage in one opening.

WARNING

ELECTRIC SHOCK HAZARD

Can cause injury or death.

Foil-faced insulation has conductive characteristics similar to metal. Be sure there are no electrical connections within a 1/2" of the insulation. If the foil-faced insulation comes in contact with electrical voltage, the foil could provide a path for current to pass through to the outer metal cabinet. While the current produced may not be enough to trip existing electrical safety devices (e.g. fuses or circuit breakers), the current can be enough to cause an electric shock hazard that could cause personal injury or death.

WARNING

ELECTRIC SHOCK HAZARD



Can cause injury or death. Unit must be grounded in accordance with national and local codes.

Line voltage is present at all components when unit is not in operation on units with single-pole contactors. Disconnect all remote electric power supplies before opening access panel. Unit may have multiple power supplies.

- Wiring must conform to the current National Electric Code ANSI/NFPA No. 70, or Canadian Electric Code Part I, CSA Standard C22.1, and local building codes. Refer to following wiring diagrams. See unit nameplate for minimum circuit ampacity and maximum over-current protection size.
- Electrical wiring, disconnect means and over-current protection are to be supplied by the installer. Refer to the air handler rating plate for maximum over-current protection, minimum circuit ampacity, as well as operating voltage. Select the proper supply circuit conductors in accordance with tables 310-16 and 310-17 in the National Electric Code, ANSI/NFPA No. 70 or tables 1 through 4 in the Canadian Electric Code, Part I, CSA Standard C22.1.

- The power supply must be sized and protected according to the specifications supplied on the product.
- This air handler is factory-configured for 240 volt, single phase, 60 cycles. For 208-volt applications, see “208 Volt Conversion” later in this section.
- Separate openings have been provided for 24V low voltage and line voltage. Refer to the dimension illustration for specific location.
- This unit is provided with holes for conduit. Use provided caps to seal holes not used.
- Typical unit wiring (as well as wiring of optional field-installed electric heat) is given in figure 17. Refer to the instructions provided with the electric heat section for proper installation.
- See figure 18 for typical low voltage field wiring connections.
- For optional field-installed electric heat applications, refer to the instructions provided with the accessory for proper installation.

208 Volt Conversion

1. Disconnect all power supplies.
2. Remove the air handler access panel.
3. Using the wiring diagram located on the unit access panel as a reference, move the black transformer leads from the 240-volt terminal on the transformer to the 208-volt terminal on the transformer. See figure 16.

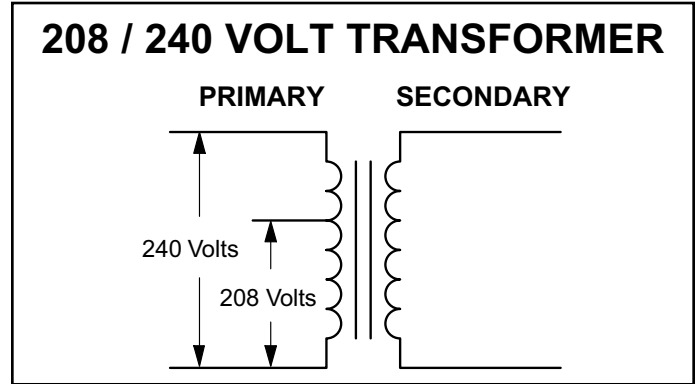

Figure 16

⚠ WARNING

USE COPPER CONDUCTORS ONLY!

1. Disconnect all power supplies.
2. Remove the air handler access panel.
3. Route the field supply wires to the air handler electrical connection box.
4. Use UL-listed wire nuts to connect the field supply conductors to the unit black and yellow leads, and the ground wire to ground terminal marked GND.
5. Replace the air handler access panel.

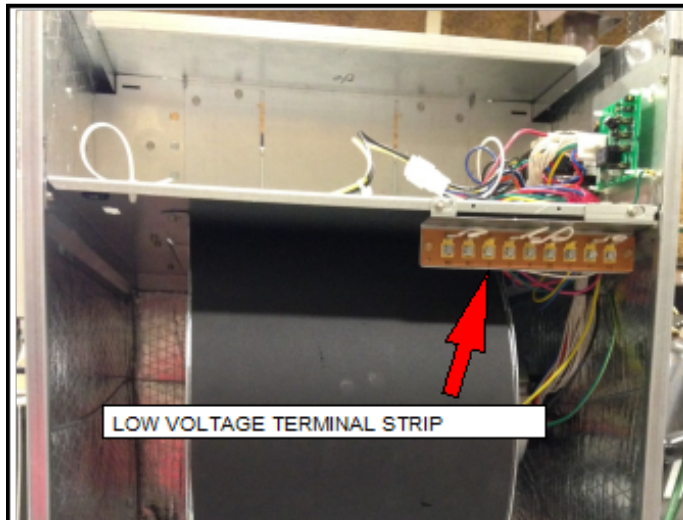

Figure 15. Electrical Connections (Upflow Configuration)

SYSTEM	FIELD JUMPERS
SINGLE STAGE AIR CONDITIONER	NEED ALL
TWO-STAGE AIR CONDITIONER	REMOVE Y1 TO Y2
SINGLE STAGE HEAT PUMP	REMOVE R TO O
TWO-STAGE HEAT PUMP	REMOVE Y1 TO Y2 AND R TO O
TWO-STAGE ELECTRIC HEAT	REMOVE W1 TO W2
TO ACTIVATE DEHUMIDIFICATION	REMOVE R TO DS

WARNING

USE COPPER CONDUCTORS ONLY

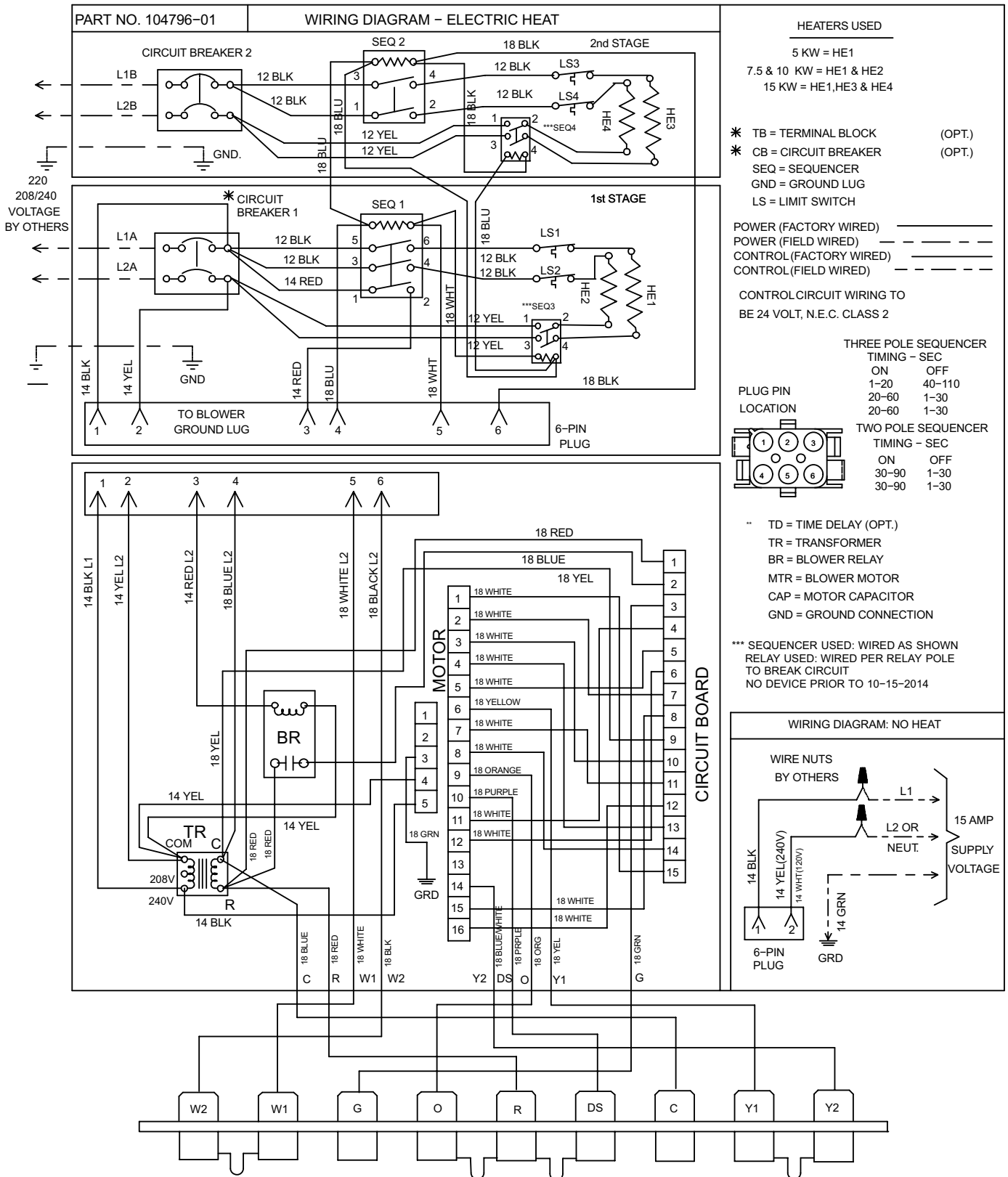
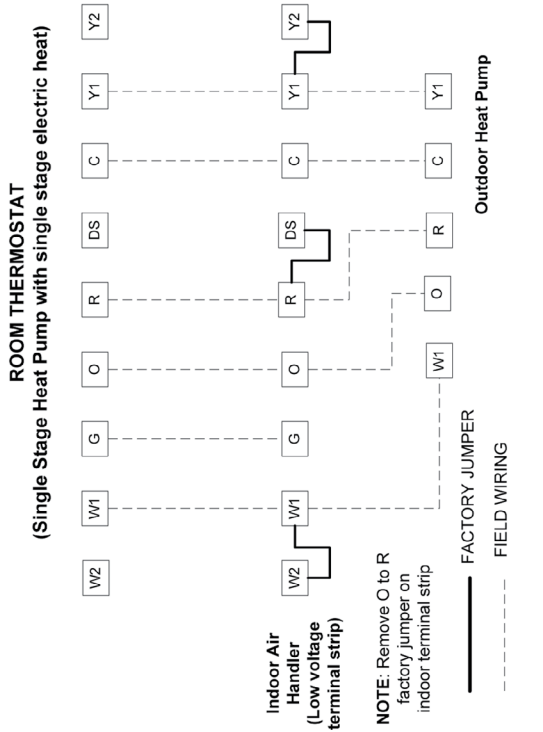
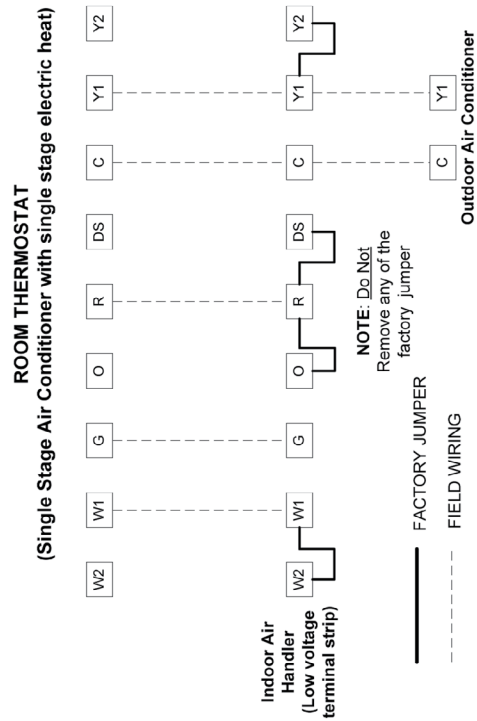

Figure 17. Typical Wiring Diagram - HCG*V Air Handler with Electric Heat



To operate indoor blower at the dehumidification air volume:
Remove the factory jumper between DS and R. Connect DS terminal in air handler to DS in room thermostat.



To operate indoor blower at the dehumidification air volume:
Remove the factory jumper between DS and R. Connect DS terminal in air handler to DS in room thermostat.

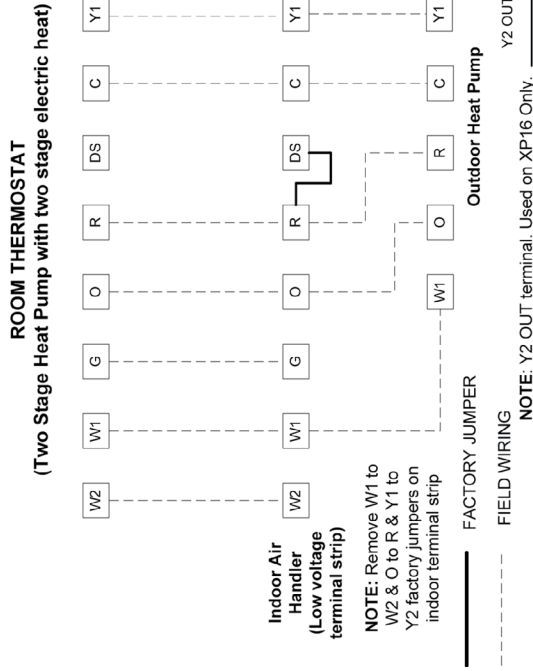

To operate indoor blower at the dehumidification air volume:
Remove the factory jumper between DS and R. Connect DS terminal in air handler to DS in room thermostat.

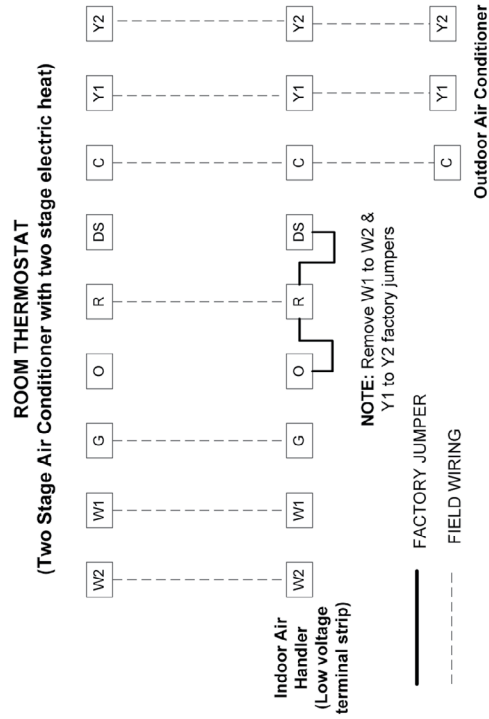

To operate indoor blower at the dehumidification air volume:
Remove the factory jumper between DS and R. Connect DS terminal in air handler to DS in room thermostat.

WARNING
USE COPPER CONDUCTORS ONLY

Figure 18. Low Voltage Connections

Blower Control

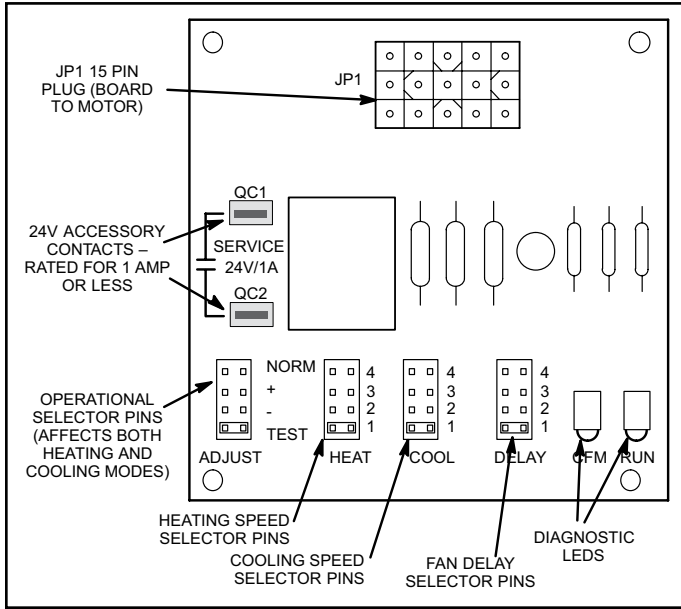

Figure 19. Variable Speed Control Selections

HCG*V units are equipped with a variable-speed motor that is capable of maintaining a specified CFM throughout the external static range. A particular CFM can be obtained by positioning jumpers (COOL, HEAT, and ADJUST) on the blower control.

The jumpers are labeled 1, 2, 3, and 4. This indicates the selected air volume (CFM).

- The ADJUST jumper is labeled Test, -, +, and Norm. The - and + pin settings are used to add or subtract a percentage of the CFM selected.
- The Test jumper is used to operate the motor in the test mode.
- The delay jumper controls the timing pattern in which the fan delay occurs.

Figure 19 illustrates the blower control. Use either table 5 or table 6 to determine the correct air volume for heat and cool speed taps.

Diagnostic LEDs located on the blower control assist in servicing the unit. Read the jumper settings section before adjusting blower speed. Refer to figure 19 for identification.

Adjusting the Blower Speed

Diagnostic LEDs

1. RUN LED indicates there is a demand for the blower motor to run.
2. CFM LED indicates the cubic feet per minute at which the unit is operating. The light flashes once for approximately every 100 CFM. For example, if the

unit is operating at 1000 CFM, CFM LED will flash 10 times. If the CFM is 1150, CFM LED will flash 11 full times plus one fast or half flash.

At times, the light may appear to flicker or glow. This is normal and occurs when the control is communicating with the motor between cycles.

Move the jumper pins to select the blower speed needed to meet application CFM requirements.

Jumper Settings

▲ IMPORTANT

Before changing jumper setting, make sure the motor has completely stopped. Any jumper setting change will not take place while the motor is running.

Table 3 lists the recommended factory blower speed tap selections for HCG*V series units. These settings are for nominal tonnage match-ups with the HCG*V. When matched with other sizes, it is recommended that the CFM be adjusted to provide approximately 400 CFM per ton.

Table 2. Recommended Blower Speed Taps

Air Handler	Speed Tap Selection			
	Cooling		Heating*	
	Note 1 -	Note 2 -	Note 3 -	Note 4 -
-024	COOL PIN #3	COOL PIN #3	HEAT PIN #2+	HEAT PIN #2+
-036	COOL PIN #3	COOL PIN #3	HEAT PIN #2	HEAT PIN #2
-042	COOL PIN #3	COOL PIN #3	HEAT PIN #2	HEAT PIN #2
-048	COOL PIN #3-	COOL PIN #3-	HEAT PIN #2	HEAT PIN #2
-060	COOL PIN #3-	COOL PIN #3-	HEAT PIN #2	HEAT PIN #2

NOTES -

- 1 - Condensing Unit
- 2 - Heat Pump
- 3 - Condensing Unit with electric heat only
- 4 - Heat Pump with electric heat

* Minimum setting for heat

To change jumper positions, gently pull the jumper off the pins and insert it onto the desired set of pins. The following section outlines the different jumper selections available and conditions associated with each one as illustrated in figure 19.

After the CFM for each application has been determined, the jumper settings must be adjusted to reflect those given in the appropriate tables on the following pages. From the tables, determine which row of CFM volumes most closely matches the desired CFM. Once a specific row has been chosen (+, NORMAL, or -), CFM volumes from other rows cannot be used. Below are descriptions of the jumper selections.

ADJUST Jumper

The ADJUST pins allow the motor to run at normal speed, slightly higher (approximately 10%) than normal speed, or slightly lower (approximately 10%) than normal speed. The tables on the following pages list three rows (+, NORMAL, and -) with their respective CFM volumes. Notice in table 4, for example, that the normal adjustment setting for heat speed position #4 is 1000 CFM. The + adjustment setting for that position is 1080 CFM and for the - adjustment setting is 910 CFM. After the adjustment setting has been determined, choose the remaining speed jumper settings from those offered in the table in that row.

The TEST pin is available to bypass the blower control and run the motor at approximately 70% to test that the motor is operational. This is beneficial primarily in troubleshooting. G must be energized for motor to run.

COOL Jumper

The COOL jumper is used to determine the CFM during either cooling or heat pump operation without a call for electric heat. These jumper selections are activated for cooling when Y2 and DS terminals in the HCG*V are energized. They are activated for heating when Y2 is energized.

The HCG*V will provide 70% of the COOL CFM during first-stage cooling for two-stage outdoor units. 100% of COOL speed is provided for systems with a single-stage outdoor unit.

With the thermostat set for Continuous Fan and without a call for heating or cooling, the HCG*V provides 50% of the COOL CFM selected.

NOTE - For two-stage heat pumps, air handler will operate at 70% of the COOL selection until supplemental electric heat is demanded. At that time, the air handler will operate at the selected HEAT speed. This arrangement provides warmer supply air during second-stage heating.

HEAT Jumper

The HEAT jumper is used to determine CFM during electric heat operation only. These jumper selections are activated only when W1 is energized.

DELAY Jumper

The DELAY jumper is used to set the specific motor fan operation during cooling mode. Depending on the application, one of four options may be chosen by moving the jumper to the appropriate set of pins.

#1 Pins Jumpered

- A- Motor runs at 100% until demand is satisfied.
- B- Once demand is met, motor ramps down to stop.

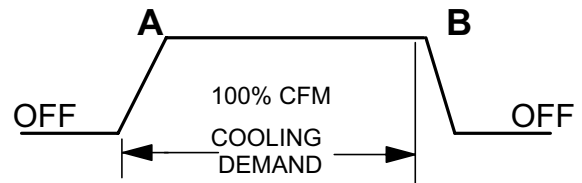

HCG24V Air Handler Performance (0 through 0.80 in. w.g. [0 - 200 Pa] External Static Pressure Range)

"ADJUST" Jumper Setting	Jumper Speed Positions											
	"HEAT" Speed				First-Stage "COOL" Speed				Second-Stage "COOL" Speed			
	1	2	3	4	1	2	3	4	1	2	3	4
	cfm	cfm	cfm	cfm	cfm	cfm	cfm	cfm	cfm	cfm	cfm	cfm
+	470	690	900	1120	350	470	625	775	480	670	890	1125
NORM	430	640	810	1020	330	450	580	720	430	605	820	1020
-	410	550	720	900	300	405	505	650	390	545	740	930

NOTES

- The effect of static pressure, filter and electric heater resistance is included in the air volumes listed.
- First-stage cooling air volume is 70% of COOL (second-stage) speed setting. Continuous blower speed is approximately 50% of COOL speed setting.

HCG36V Air Handler Performance (0 through 0.80 in. w.g. [0 - 200 Pa] External Static Pressure Range)

"ADJUST" Jumper Setting	Jumper Speed Positions											
	"HEAT" Speed				First-Stage "COOL" Speed				Second-Stage "COOL" Speed			
	1	2	3	4	1	2	3	4	1	2	3	4
	cfm	cfm	cfm	cfm	cfm	cfm	cfm	cfm	cfm	cfm	cfm	cfm
+	880	1115	1345	1435	615	770	930	1090	880	1110	1340	1435
NORM	800	1010	1215	1425	555	695	845	990	795	1005	1215	1420
-	715	905	1095	1275	505	625	755	885	715	905	1090	1280

NOTES

- The effect of static pressure, filter and electric heater resistance is included in the air volumes listed.
- First-stage cooling air volume is 70% of COOL (second-stage) speed setting. Continuous blower speed is approximately 50% of COOL speed setting.

HCG42V Air Handler Performance (0 through 0.80 in. w.g. [0 - 200 Pa] External Static Pressure Range)

"ADJUST" Jumper Setting	Jumper Speed Positions											
	"HEAT" Speed				First-Stage "COOL" Speed				Second-Stage "COOL" Speed			
	1	2	3	4	1	2	3	4	1	2	3	4
	cfm	cfm	cfm	cfm	cfm	cfm	cfm	cfm	cfm	cfm	cfm	cfm
+	1115	1345	1560	1800	800	960	1120	1265	1130	1360	1580	1800
NORM	1025	1215	1415	1630	730	870	1020	1150	1040	1240	1450	1640
-	925	1110	1280	1460	650	790	915	1050	950	1120	1290	1470

NOTES

- The effect of static pressure, filter and electric heater resistance is included in the air volumes listed.
- First-stage cooling air volume is 70% of COOL (second-stage) speed setting. Continuous blower speed is approximately 50% of COOL speed setting.

HCG48V Air Handler Performance (0 through 0.80 in. w.g. [0 - 200 Pa] External Static Pressure Range)

"ADJUST" Jumper Setting	Jumper Speed Positions											
	"HEAT" Speed				First-Stage "COOL" Speed				Second-Stage "COOL" Speed			
	1	2	3	4	1	2	3	4	1	2	3	4
	cfm	cfm	cfm	cfm	cfm	cfm	cfm	cfm	cfm	cfm	cfm	cfm
+	1450	1670	1880	2340	1050	1200	1340	1650	1440	1670	1950	2340
NORM	1340	1520	1730	2100	950	1100	1230	1520	1325	1530	1740	2150
-	1210	1390	1570	1915	850	1000	1110	1375	1200	1380	1600	1950

NOTES

- The effect of static pressure, filter and electric heater resistance is included in the air volumes listed.
- First-stage cooling air volume is 70% of COOL (second-stage) speed setting. Continuous blower speed is approximately 50% of COOL speed setting.

HCG60V Air Handler Performance (0 through 0.80 in. w.g. [0 - 200 Pa] External Static Pressure Range)

"ADJUST" Jumper Setting	Jumper Speed Positions											
	"HEAT" Speed				First-Stage "COOL" Speed				Second-Stage "COOL" Speed			
	1	2	3	4	1	2	3	4	1	2	3	4
	cfm	cfm	cfm	cfm	cfm	cfm	cfm	cfm	cfm	cfm	cfm	cfm
+	1700	1930	2120	2275	1225	1410	1530	1690	1720	1930	2140	2270
NORM	1570	1760	1925	2100	1120	1260	1400	1540	1580	1765	1970	2100
-	1420	1595	1760	1920	1015	1160	1275	1390	1430	1625	1780	1890

NOTES

- The effect of static pressure, filter and electric heater resistance is included in the air volumes listed.
- First-stage cooling air volume is 70% of COOL (second-stage) speed setting. Continuous blower speed is approximately 50% of COOL speed setting.

HCG*V Thermostat and Single-Stage Outdoor Unit Operating Sequence

Operating Sequence		System Demand						System Response			
System Condition	Step	Thermostat Demand			Relative Humidity			Compressor	Air Handler CFM (COOL)	Comments	
		Y1	Y2	O	G	W1	W2				Status
NO CALL FOR DEHUMIDIFICATION											
Normal Operation	1	On		On			Acceptable	24 VAC	High	100%	Compressor and indoor air handler follow thermostat demand
BASIC MODE (only active on a Y1 thermostat demand)											
Normal Operation	1	On		On			Acceptable	24 VAC	High	100%	Thermostat energizes Y1 and de-energizes D on a call for dehumidification
Dehumidification Call	2	On		On			Demand	0 VAC	High	60%/65% 70%*	
PRECISION MODE (operates independent of a Y1 thermostat demand)											
Normal Operation	1	On		On			Acceptable	24 VAC	High	100%	Dehumidification mode begins when humidity is greater than set point
Dehumidification Call	2	On		On			Demand	0 VAC	High	60%/65% 70%*	
Dehumidification Call ONLY	1	On		On			Demand	0 VAC	High	60%/65% 70%*	Thermostat will try to maintain room humidity setpoint by allowing the room space to maintain a cooler room thermostat setpoint**
	Jumpers at indoor unit with a single stage outdoor unit With Condensing unit - Y1 to Y2 and R to O With Heat Pump - Y1 to Y2										
<p>* During dehumidification, cooling air handler speed is as follows: 70% of COOL cfm for 024; 65% for 036; 60% for 042, 048 and 060 units.</p> <p>** Thermostat will maintain the room temperature up to 2°F (1.2°C) cooler than the room thermostat setting in precision mode.</p>											

HCG*V Thermostat and Two-Stage Outdoor Unit Operating Sequence

Operating Sequence		System Demand						System Response				
System Condition	Step	Thermostat Demand						Compressor	Air Handler CFM (COOL)	Comments		
		Y1	Y2	O	G	W1	W2				Relative Humidity Status	D
NO CALL FOR DEHUMIDIFICATION												
Normal Operation - Y1	1	On		On	On			Acceptable	24 VAC	Low	70%	Compressor and indoor air handler follow thermostat demand
Normal Operation - Y2	2	On	On	On	On			Acceptable	24 VAC	High	100%	
Room Thermostat Calls for First-Stage Cooling												
BASIC MODE (only active on a Y1 thermostat demand)												
Normal Operation	1	On		On	On			Acceptable	24 VAC	Low	70%	Thermostat energizes Y2 and de-energizes D on a call for dehumidification
Dehumidification Call	2	On	On	On	On			Demand	24 VAC	High	60%/65% 70%*	
PRECISION MODE (operates independent of a Y1 thermostat demand)												
Normal Operation	1	On		On	On			Acceptable	24 VAC	Low	70%	Dehumidification mode begins when humidity is greater than set point
Dehumidification Call	2	On	On	On	On			Demand	0 VAC	High	60%/65% 70%*	
Dehumidification Call ONLY	1	On	On	On	On			Demand	0 VAC	High	60%/65% 70%*	Thermostat will try to maintain room humidity setpoint by allowing the room space to maintain a cooler room thermostat setpoint**
Jumpers at indoor unit with a two-stage outdoor unit With Condensing unit - Y2 and R to O With Heat Pump - none												
* During dehumidification, cooling air handler speed is as follows: 70% of COOL cfm for 024; 65% for 036; 60% for 042, 048 and 060 units. ** Thermostat will maintain the room temperature up to 2°F (1.2°C) cooler than the room thermostat setting in precision mode.												

HCG*V Thermostat and Two-Stage Outdoor Unit Operating Sequence, Continued

Operating Sequence		System Demand							System Response		
System Condition	Step	Thermostat Demand			Relative Humidity		Compressor	Air Handler CFM (COOL)	Comments		
		Y1	Y2	O	G	W1				W2	Status
Room Thermostat Calls for First- and Second-Stage Cooling											
BASIC MODE (only active on a Y1 thermostat demand)											
Normal Operation	1	On	On	On	On		Acceptable	24 VAC	High	100%	Thermostat energizes Y2 and de-energizes D on a call for dehumidification
Dehumidification Call	2	On	On	On	On		Demand	0 VAC	High	60%/65% 70%*	
PRECISION MODE (operates independent of a Y1 thermostat demand)											
Normal Operation	1	On	On	On	On		Acceptable	24 VAC	High	100%	Dehumidification mode begins when humidity is greater than set point
Dehumidification Call	2	On	On	On	On		Demand	0 VAC	High	60%/65% 70%*	
Dehumidification Call ONLY	1	On	On	On	On		Demand	0 VAC	High	60%/65% 70%*	Thermostat will try to maintain room humidity setpoint by allowing the room space to maintain a cooler room thermostat setpoint**
Jumpers at indoor unit with a two-stage outdoor unit With Condensing unit - Y2 and R to O With Heat Pump - none											
* During dehumidification, cooling air handler speed is as follows: 70% of COOL cfm for 024; 65% for 036; 60% for 042, 048 and 060 units. ** Thermostat will maintain the room temperature up to 2°F (1.2°C) cooler than the room thermostat setting in precision mode.											

#2 Pins Jumpered

- A- Motor runs at 100% until demand is satisfied.
- B- Once demand is met, motor runs at 100% for 60 seconds.
- C- Motor ramps down to stop.

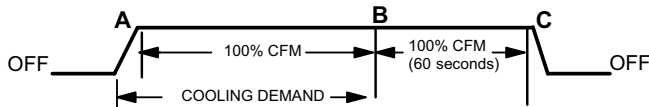

#3 Pins Jumpered

- A- Motor runs at 82% for approximately 7-1/2 minutes. If demand has not been satisfied after 7-1/2 minutes -
- B- Motor runs at 100% until demand is satisfied.
- C- Once demand is met, motor ramps down to stop.

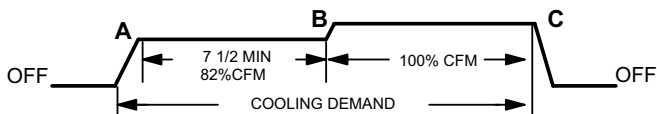

#4 Pins Jumpered

- A- Motor runs at 50% for 30 seconds.
- B- Motor then runs at 82% for approximately 7-1/2 minutes. If demand has not been satisfied after 7-1/2 minutes,
- C- Motor runs at 100% until demand is satisfied.
- D- Once demand is met, motor runs at 50% for 30 seconds.
- E- Motor ramps down to stop.

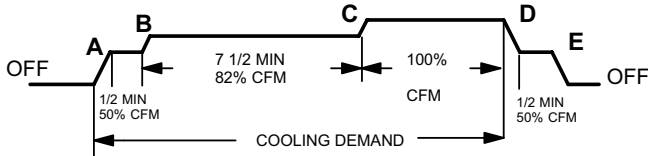

Check-Out Procedures

NOTE: Refer to outdoor unit installation instructions for system start-up instructions and refrigerant charging instructions.

Pre-Start-Up Checks

- Is the air handler properly and securely installed?
- If horizontally configured, is the unit sloped up to 5/8" toward drain lines?
- Will the unit be accessible for servicing?
- Has a secondary (auxiliary) pan been provided under the unit with separate drain for units installed above a finished ceiling or in any installation where condensate overflow could cause damage?
- Have ALL unused drain pan ports been properly plugged?

- Has the condensate line been properly sized, run, trapped, pitched and tested?
- Is the duct system correctly sized, run, sealed and insulated?
- Have all cabinet openings and wiring been sealed?
- Is the indoor coil factory-installed TXV properly sized for the outdoor unit being used?
- Have all unused parts and packaging been disposed of properly?
- Is the filter clean, in place and adequately size?
- Is the wiring neat, correct and in accordance with the wiring diagram?
- Is the unit properly grounded and protected (fused)?
- Is the thermostat correctly wired and in a good location?
- Are all access panels in place and secure?

Check Blower Operation

- Set thermostat to FAN ON.
- The indoor blower should come on.

Check Cooling Operation

- Set thermostat to force a call for cooling (approximately 5°F lower than the indoor ambient temperature).
- The outdoor and indoor units should come on immediately.
- Check the airflow from a register to confirm that the system is moving cooled air.
- Set the thermostat 5°F higher than the indoor temperature. The indoor blower and outdoor unit should cycle off. Air handler should cycle off 45 seconds after the outdoor unit shuts off.

Check Electric Heater (if used)

- Set thermostat to call for auxiliary heat (approximately 5°F above ambient temperature). The indoor blower and auxiliary heat should come on together. Allow a minimum of 3 minutes for all sequencers to cycle on.
- Set the thermostat so that it does not call for heat. Allow up to 5 minutes for all sequencers to cycle off.

Maintenance

IMPORTANT

Do not operate system without a filter. A filter is required to protect the coil, blower, and internal parts from excessive dirt and dust. The filter is placed in the return duct by the installer.

- Inspect air filters at least once a month and replace or clean as required. Dirty filters are the most common cause of inadequate heating or cooling performance.
- Replace disposable filters. Cleanable filters can be cleaned by soaking in mild detergent and rinsing with cold water.
- Install new/clean filters with the arrows on the side pointing in the direction of airflow. Do not replace a cleanable (high velocity) filter with a disposable (low velocity) filter unless return air system is properly sized for it.
- If water is seen dripping from the secondary drain line, contact a qualified service technician. This is a sign of a problem that must be investigated and corrected.

Cabinet Insulation

IMPORTANT

DAMAGED INSULATION MUST BE REPAIRED OR REPLACED before the unit is put back into operation. Insulation loses its insulating value when wet, damaged, separated or torn.

Matte- or foil-faced insulation is installed in indoor equipment to provide a barrier between outside air conditions (surrounding ambient temperature and humidity) and the varying conditions inside the unit. If the insulation barrier is damaged (wet, ripped, torn or separated from the cabinet walls), the surrounding ambient air will affect the inside surface temperature of the cabinet. The temperature/humidity difference between the inside and outside of the cabinet can cause condensation on the inside or outside of the cabinet, which leads to sheet metal corrosion and subsequently, component failure.

Repairing Damaged Insulation

Areas of condensation on the cabinet surface are an indication that the insulation is in need of repair.

If the insulation in need of repair is otherwise in good condition, the insulation should be cut in an X pattern, peeled open, glued with an appropriate all-purpose glue

and placed back against the cabinet surface, being careful to not overly compress the insulation so the insulation can retain its original thickness. If such repair is not possible, replace the insulation. If using foil-faced insulation, any cut, tear, or separations in the insulation surface must be taped with a similar foil-faced tape.

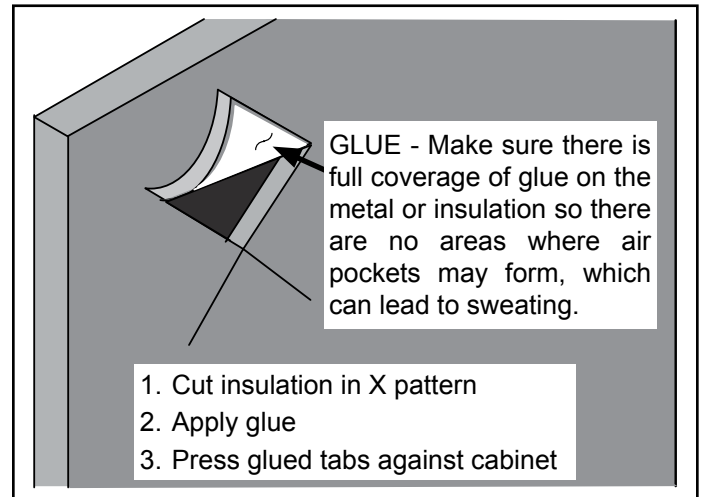

Figure 20. Repairing Insulation

Use of Air Handler During Construction

Comfort-Aire / Century does not recommend the use of its air handler unit during any phase of construction. Very low return air temperatures, harmful vapors and operation of the unit with clogged or misplaced filters will damage the unit.

Air handler units may be used for heating (heat pumps) or cooling of buildings under construction, if the following conditions are met:

- A room thermostat must control the air handler. The use of fixed jumpers is not allowed.
- Air filter must be installed in the system and must be maintained during construction.
- Air filter must be replaced upon construction completion.
- The air handler evaporator coil, supply fan assembly and duct system must be thoroughly cleaned following final construction clean-up.
- All air handler operating conditions must be verified according to these installation instructions.

Installing Contractor's Name _____

Installing Contractor's Phone _____

Air Handler Model # _____

Job Address _____

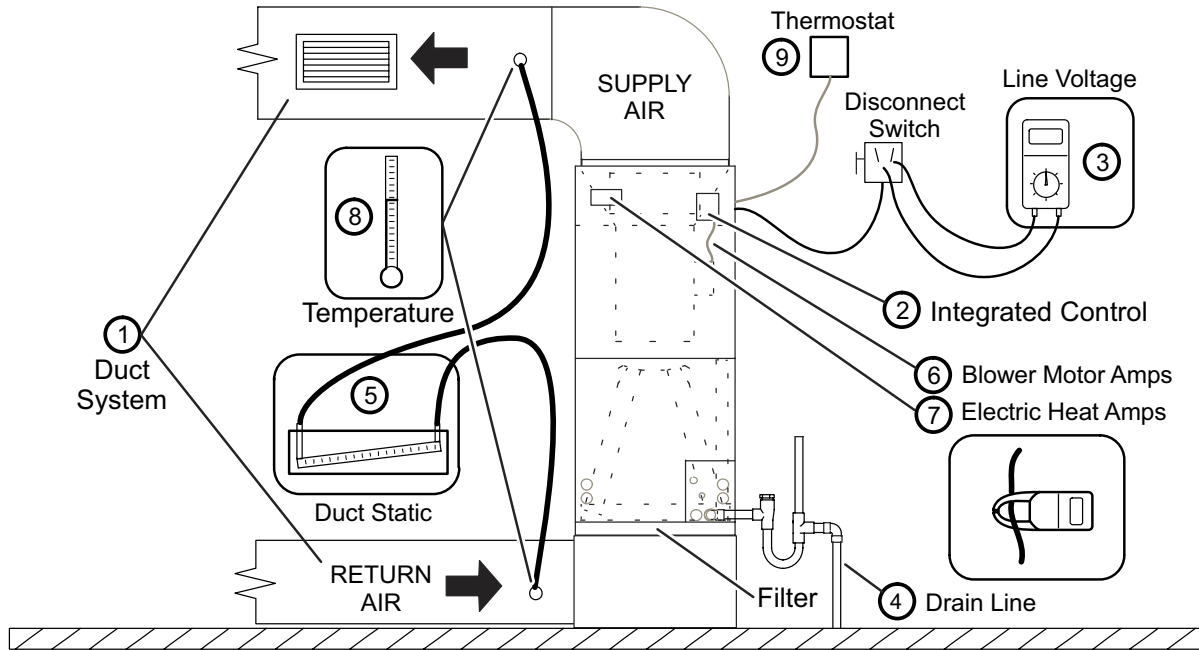

- ① DUCT SYSTEM
 - SUPPLY AIR DUCT
 - Sealed
 - Insulated (if necessary)
 - Registers Open and Unobstructed
 - RETURN AIR DUCT
 - Sealed
 - Filter Installed and Clean
 - Registers Open and Unobstructed
- ② INTEGRATED CONTROL
 - Jumpers Configured Correctly (if applicable)
 - Appropriate Links in Place (if applicable)
- ③ VOLTAGE CHECK
 - Supply Voltage _____
 - Low Voltage _____
 - Electrical Connections Tight
- ④ DRAIN LINE
 - Leak Free
- ⑤ TOTAL EXTERNAL STATIC (dry coil)

	dry coil	wet coil
Supply External Static	_____	_____
Return External Static	_____	_____
Total External Static =	_____	_____
- ⑥ ELECTRIC HEAT AMPS _____
- ⑦ INDOOR BLOWER AMPS _____
INDOOR BLOWER CFM _____
- ⑧ TEMPERATURE DROP (Cooling Mode)

Return Duct Temperature	_____
Supply Duct Temperature -	_____
Temperature Drop =	_____
- ⑧ TEMPERATURE RISE (Heating Mode)

Return Duct Temperature	_____
Supply Duct Temperature -	_____
Temperature Rise =	_____
- ⑨ THERMOSTAT
 - Adjusted and Programmed
 - Operation Explained to Owner

Explained Operation of System to Homeowner

Technician's Name: _____ Date Start-Up & Performance Check Completed _____

Figure 21. Start-Up and Performance Checklist (Upflow Configuration)

Installing Contractor's Name _____ Installing Date _____
 Installing Contractor's Phone _____ Air Handler Model # _____
 Job Address _____

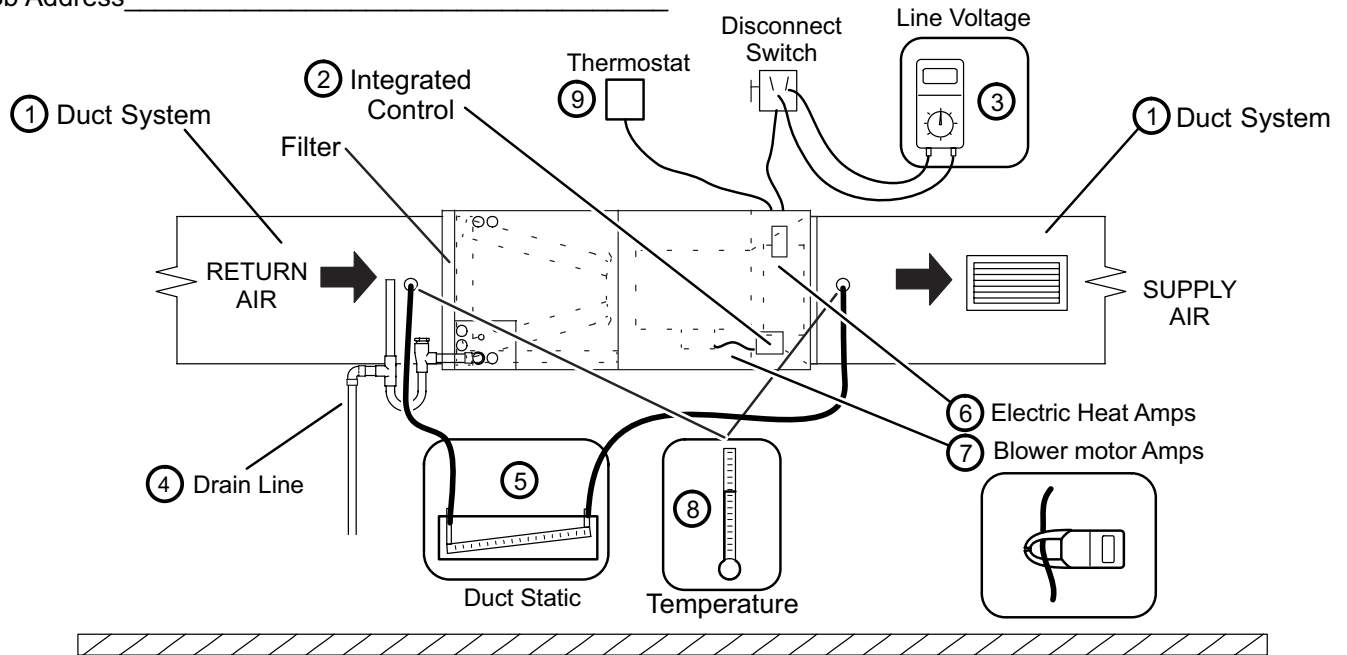

- | | |
|-------------------------------------------------------------------------------------------------------------------------------------------------------------------------------------------------------------------------------------------------------------------------------------------------------------------------------------------------------------------------------------------------------------------------------------------------------------------------------------------------------------------------------------------------------------------------------------------------------------------------------------------------------------------------------------------------------------------------------------------------------------------------------------------------------------------------------------------------------------------------------|---------------------------------------------------------------------------------------------------------------------------------------------------------------------------------------------------------------------------------------------------------------------------------------------------------------------------------------------------------------------------------------------------------------------------------------------------------------------------------------------------------------------------------------------------------------------------------------------------------------------------------------------------------------------------------------------------------------------------------------------------------------------------------------------------------------|
| <p>① DUCT SYSTEM</p> <p>SUPPLY AIR DUCT</p> <p><input type="checkbox"/> Sealed</p> <p><input type="checkbox"/> Insulated (if necessary)</p> <p><input type="checkbox"/> Registers Open and Unobstructed</p> <p>RETURN AIR DUCT</p> <p><input type="checkbox"/> Sealed</p> <p><input type="checkbox"/> Filter Installed and Clean</p> <p><input type="checkbox"/> Registers Open and Unobstructed</p> <p>② INTEGRATED CONTROL</p> <p><input type="checkbox"/> Jumpers Configured Correctly (if applicable)</p> <p><input type="checkbox"/> Appropriate Links in Place (if applicable)</p> <p>③ VOLTAGE CHECK</p> <p><input type="checkbox"/> Supply Voltage _____</p> <p><input type="checkbox"/> Low Voltage _____</p> <p><input type="checkbox"/> Electrical Connections Tight</p> <p>④ DRAIN LINE</p> <p><input type="checkbox"/> Leak Free</p> | <p>⑤ TOTAL EXTERNAL STATIC (dry coil)</p> <p style="text-align: right;">dry coil wet coil</p> <p>Supply External Static _____</p> <p>Return External Static _____</p> <p>Total External Static = _____</p> <p>⑥ ELECTRIC HEAT AMPS _____</p> <p>⑦ INDOOR BLOWER AMPS _____</p> <p>INDOOR BLOWER CFM _____</p> <p>⑧ TEMPERATURE DROP (Cooling Mode)</p> <p>Return Duct Temperature _____</p> <p>Supply Duct Temperature - _____</p> <p>Temperature Drop = _____</p> <p>⑧ TEMPERATURE RISE (Heating Mode)</p> <p>Return Duct Temperature _____</p> <p>Supply Duct Temperature - _____</p> <p>Temperature Rise = _____</p> <p>⑨ THERMOSTAT</p> <p><input type="checkbox"/> Adjusted and Programmed</p> <p><input type="checkbox"/> Operation Explained to Owner</p> |
|-------------------------------------------------------------------------------------------------------------------------------------------------------------------------------------------------------------------------------------------------------------------------------------------------------------------------------------------------------------------------------------------------------------------------------------------------------------------------------------------------------------------------------------------------------------------------------------------------------------------------------------------------------------------------------------------------------------------------------------------------------------------------------------------------------------------------------------------------------------------------------|---------------------------------------------------------------------------------------------------------------------------------------------------------------------------------------------------------------------------------------------------------------------------------------------------------------------------------------------------------------------------------------------------------------------------------------------------------------------------------------------------------------------------------------------------------------------------------------------------------------------------------------------------------------------------------------------------------------------------------------------------------------------------------------------------------------|

Explained Operation of System to Homeowner

Technician's Name: _____ Date Start-Up & Performance Check Completed _____

Figure 22. Start-Up and Performance Checklist (Horizontal Configuration)