

---

# Comfort-Aire®

---

## OWNER'S MANUAL

### Model

9" Plastic Window Fan  
FW-0930Dxx-PWH

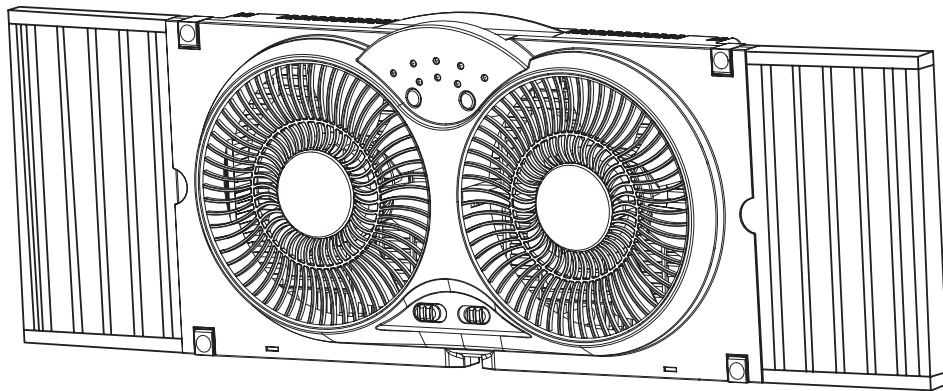

# IMPORTANT SAFETY INSTRUCTIONS

*Read Rules for Safe Operation and Instructions Carefully*

## WARNING, RULES FOR SAFE OPERATION, USER SERVICING INSTRUCTION, CLEANING:

1. This appliance has a polarized plug (one blade is wider than the other). To reduce the risk of electric shock, this plug is intended to fit in a polarized outlet only one way. If plug does not fit fully in the outlet, reverse the plug. If it still does not fit, contact a qualified electrician. Do not attempt to defeat this safety feature.
2. To reduce the risk of fire or electric shock, DO NOT use this fan with any solid-state speed control devices.
3. Do not leave the fan running unattended.

## RULES FOR SAFE OPERATION

1. Never insert fingers, pencils, or any other object through the grille when fan is running.
2. Disconnect fan when moving from one location to another.
3. Be sure fan is on a stable surface when operating to avoid overturning.
4. Ensure that the fan is switched off from the supply mains before removing the grille.
5. Automatically operated device - to reduce the risk of injury, disconnect from power supply before servicing.
6. To reduce the risk of personal injury and electric shock, it should not be played with or placed where small children can reach it.
7. Do not operate any fan with a damaged cord or plug. Discard fan or return to an authorized service facility for examination and/or repair.
8. Do not run cord under carpeting. Do not cover cord with throw rugs, runners, or similar coverings. Do not route cord under furniture or appliances. Arrange cord away from traffic area where it will not be tripped over.
9. This product employs overload protection (fuse). A blown fuse indicates an overload or short-circuit situation. If the fuse blows, unplug the product from the outlet. Replace the fuse as per the user servicing instructions (follow product marking for proper fuse rating) and check the products. If the replacement fuse blows, a short-circuit may be present and the product should be discarded or returned to an authorized service facility for examination and/or repair.

## INSTALLATION INSTRUCTIONS

### Name of components

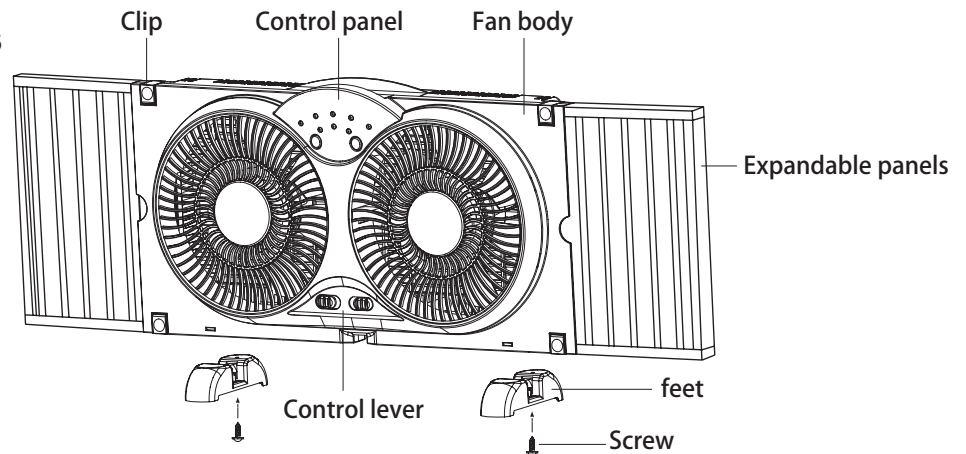

### Window Installation

1. Pull four clamps of the window body, adjust the length of the stretching baffle according to the width of the window, then compress the four clamps, and fix the length of the baffle. The stretching length of the unilateral stretching baffle is 0-7 in. (0-180mm)
2. Place the window body on the window lattice, and pull down the window to be clamped in the window body.

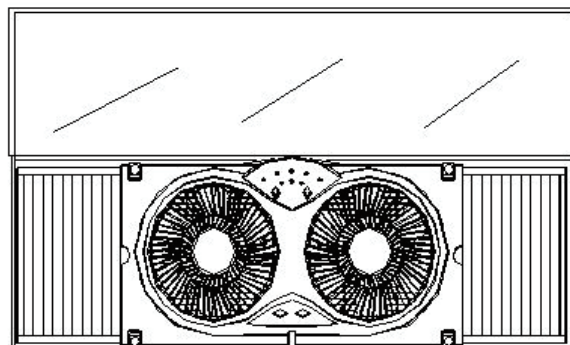

## INSTRUCTIONS FOR USE

### Control Panel

- Wind speed operation:  
When you press the wind speed key, the fan operates according to "low - medium - high - off", and the corresponding indicator light illuminates.  
1 - low speed; 2 - medium speed;  
3 - high speed
  - Temperature control:  
When you press the temperature key, you can set the fan start temperature. When the indoor temperature is higher than the set temperature, the fan automatically operates at the high speed. When the room temperature is below the set temperature, the fan stops.
  - Wind inlet and outlet control:  
When you toggle the transfer switch, you can control the fan inlet and outlet.
- Note: Do not toggle the switch continuously to prevent damage to the fan.

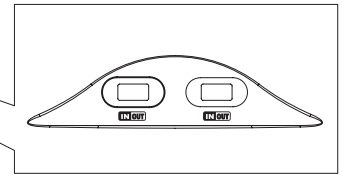
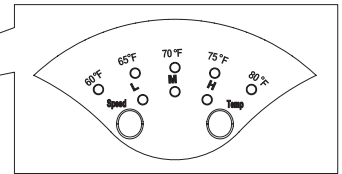
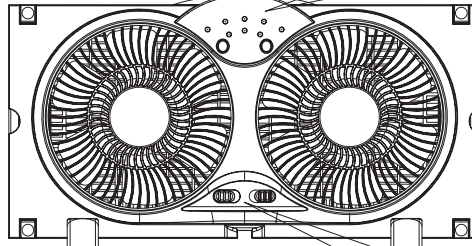

## USER SERVICING INSTRUCTIONS

- a) Grasp plug and remove from the receptacle or other outlet device. Do not unplug by pulling on cord.
- b) Open fuse cover. Slide open fuse access cover on top of attachment plug towards blades.
- c) Remove fuse carefully. Insert the tip of your tool into fuse slot (close with the terminal), then pry the fuse gradually and slowly, but not overexert. If you feel tight, you can try it at several times and pry the fuse little by little. When one side of the fuse has been pry, then you can remove the fuse out entirely.
- d) Risk of fire. Replace fuse only with 2.5 Amp, 125 Volt fuse.
- e) Close fuse cover. Slide closed the fuse access cover on top of attachment plug.
- f) Risk of fire. Do not replace attachment plug. Contains a safety device (fuse) that should not be removed. Discard product if the attachment plug is damaged.

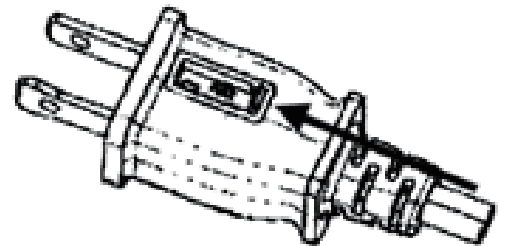

## CLEANING

1. Be sure to unplug from the electrical supply source before cleaning.
2. Plastic parts should be cleaned with mild soap and a damp cloth or sponge. Rinse to remove soap film with clean water.
3. Be sure to prevent water or other liquid from entering the motor.

# LIMITED EXPRESS WARRANTY

**Congratulations on purchasing your new HVAC equipment. It's been designed for long life and reliable service, and is backed by one of the strongest warranties in the industry. Your item automatically qualifies for the warranty coverage listed below, providing you keep your proof of purchase (receipt) for the equipment and meet the warranty conditions.**

## LIMITED ONE (1) YEAR EXPRESS WARRANTY

Comfort-Aire warrants item to be free from defects in workmanship and materials for normal use and maintenance for one (1) year from the date of purchase by the original consumer. This Express Limited Warranty applies only when operated per Comfort-Aire installation and operating instructions for normal use.

## EXCEPTIONS

The Limited Express Warranty does not cover normal maintenance Comfort-Aire recommends that regular inspection/maintenance be performed at least once a season.

## CONDITIONS FOR WARRANTY COVERAGE

Item must be operated according to Comfort-Aire operating instructions included with the unit and cannot have been subjected to accident, alteration, improper repair, neglect or misuse, or an act of God (such as a flood)

- Serial numbers and/or rating plate have not been altered or removed
- Performance cannot be impaired by use of any product not authorized by Comfort-Aire, or by any adjustments or adaptations to components
- Damage has not been a result of inadequate wiring or voltage conditions, use during brown-out conditions, or circuit interruptions

## DURATION OF WARRANTY & REGISTRATION

The warranty begins on the date of purchase by the original consumer. The consumer must retain a receipt as proof of warranty period. Without this proof, the express warranty begins on the date of shipment from the factory.

## REMEDY PROVIDED BY THE LIMITED EXPRESS WARRANTY

The sole remedy under the Limited Warranty is replacement of the defective unit. Labor to diagnose and replace the defective unit is not covered by this Limited Express Warranty. If for any reason the replacement product is no longer available during the warranty period, Comfort-Aire shall have the right to allow a credit in the amount of the current suggested retail price of the product instead of providing replacement.

## LIMITATION OF LIABILITY

1. There are no other express or implied warranties. Comfort-Aire makes no warranty of merchantability. We do not warrant that the unit is suitable for any particular purpose or can be used in buildings or rooms of any particular size or condition except as specifically provided in this document. There are no other warranties, express or implied, which extend beyond the description in this document.
2. All warranties implied by law are limited in duration to the one-term of the warranty. We will not be liable for any consequential or incidental damages caused by any defect in this item.
3. This warranty gives you specific legal rights and you may also have other rights which vary from state to state. Some states do not allow limitation on how long an implied warranty lasts or do not allow the exclusion or limitation of incidental or consequential damages, so the above limitations or exclusions may not apply to you.
4. No warranties are made for items sold outside the continental United States and Canada. Your distributor or final seller may provide a warranty on items sold outside these areas.
5. Comfort-Aire will not be liable for damages if our performance regarding warranty resolution is delayed by events beyond our control including accident, alteration, abuse, war, government restrictions, strikes, fire, flood, or other acts of God.

## HOW TO SUBMIT A WARRANTY CLAIM

If you have a warranty claim, notify you installer or dealer promptly.

## KEEP THIS INFORMATION AS A RECORD OF YOUR PURCHASE

### PRODUCT IDENTIFICATION

Model Number \_\_\_\_\_

Serial Number \_\_\_\_\_

Date of Purchase \_\_\_\_\_

Remember to retain your bill of sale as proof of warranty period.

Fans\_3-2020

Due to ongoing product improvements, specifications and dimensions are subject to change and correction without notice or incurring obligations. Determining the application and suitability for use of any product is the responsibility of the installer. Additionally, the installer is responsible for verifying dimensional data on the actual product prior to beginning any installation preparations.

Incentive and rebate programs have precise requirements as to product performance and certification. All products meet applicable regulations in effect on date of manufacture; however, certifications are not necessarily granted for the life of a product.

Therefore, it is the responsibility of the applicant to determine whether a specific model qualifies for these incentive/rebate programs.

*Comfort-Aire*®

1900 Wellworth Ave., Jackson, MI 49203 • Ph. 517-787-2100 • www.marsdelivers.com

